

QUALISCAN® QMS-12

Innovative quality control system
for the pulp and paper industry



QUALISCAN® QMS-12



INNOVATIVE QUALITY CONTROL SYSTEM
FOR THE PULP AND PAPER INDUSTRY



TEXTILE



NONWOVENS



PAPER



PLASTIC

QUALISCAN® QMS-12



The Paper Tissue and Board market requires a Quality Control System that is both flexible and configurable. Measurements must be performed on both the wet and dry ends for fast accurate control. In addition, this industry has become increasingly more competitive resulting in tighter product specifications and more challenging profit margins. Mahlo® has responded to these market pressures by providing paper industry measurement and control solutions for over 25 years.



Mahlo® PaperPro II frame integrated in Tissue Line



Mahlo's expertise and knowhow of the paper, tissue and board industries has allowed us to tailor web gauging systems for the following processes:

- Papermaking
- Tissue Manufacturing
- Board Manufacturing
- Sizing
- Remoisturizing
- Coating
- Impregnating
- Calendering
- Laminating



CONTENTS

BASIS

| | |
|------------------------|---|
| Visualization | 8 |
| Everything at a glance | |

MECHANICAL

| | |
|----------------------------|----|
| Mahlo® Qualiscan® | 10 |
| PaperPro II scanning frame | |

SENSORS

| | |
|---|----|
| Gravimat DFI | 14 |
| Weight per unit area and thickness | |
| Ashpro FMA | 16 |
| Measuring the ash content | |
| Gravimat FMX | 18 |
| Weight per unit area and thickness | |
| Aqualot HMF | 20 |
| Moisture measurement | |
| Infralot IMF | 22 |
| Moisture measurement, weight per unit area and thickness | |
| Calipro DML | 24 |
| Non-contact measurement of thickness | |
| Calipro DMP | 26 |
| Contact measurement of thickness | |
| Glosspro GMR | 28 |
| Gloss measurement - reflection | |

TECHNICAL DATA

| | |
|------------------------------|----|
| All technical data from page | 30 |
|------------------------------|----|

INNOVATIVE TECHNIQUE, TAILORED TO CUSTOMER SPECIFIC NEED



TEXTILE



NONWOVENS



PAPER



PLASTIC



Effective Solutions for Dust Handling and use under extreme environmental conditions.

For the entire range of paper, tissue and board products, Mahlo® makes a quality control system tailored to your specific application, for your specific measurement and control needs. Fixed, single-sided and dual-sided scanning platforms are available measuring coatings, basis weight, moisture and thickness plus a myriad of combined calculations on both the wet and dry ends of the machine. Multiple synchronized scanners are available as standard for coating & laminating lines. Automated control integration is possible through our relationships with major process automation suppliers. Sealed, purged and stainless steel scanners and sensors are available.

Connecting the measuring frames



One or more different scanning frames can be connected to a Qualiscan® QMS system. Connection is made via a normal network cable, a standard 230/115 V source supplies the power.

Utilizing intelligent sensor and scanner techniques, the Mahlo® QMS systems measure on-line continuously and with extreme precision and response. The computer interface is Windows XP based, is fully open and conforms to industrial communications standards. Ease of use and configurability were built in from the ground up and the menus and functions are very easy to understand with a short learning curve.

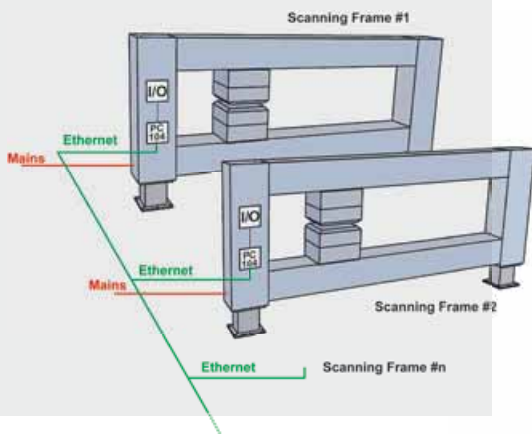

Quality made in Germany

One of the many strengths of the Mahlo® system is the family of rugged steel O-Frames. We know that these scanners must traverse back and forth around the clock, 365 days per year for many years.

Building tough industrial machinery is a forte of German manufacturing, and Mahlo® grew up making large-scale machinery for the textile and carpet industry, and continues to this day. Over-engineered for long, trouble-free life, yet easy to maintain with commercial components, all Mahlo® scanners whether single-sided for Infrared, Laser or X-Ray sensor applications, Compact O-Frames for tight spaces or the Paperpro scanner for those wide web applications and a payload of up to five sensors, are built to last.



PaperPro II Sensorload

MAHLO SUPPORT AND CUSTOMER SERVICE

The Mahlo support and service team is at your disposal with expert help whenever you need it:

Online-Support:

SERVICE@MAHLO.COM

Support-Hotline:

+49-(0)180-50 62 456

mahlo
trendsetting technology, worldwide.

MAHLO® QMS QUALITY CONTROL SYSTEM OFFERINGS



TEXTILE



NONWOVENS



PAPER



PLASTIC

Product-highlights

- ✓ Modern construction with intelligent sensors and traversing frames
- ✓ Based on industry standard hardened computers running Windows XP™ embedded operating system
- ✓ Components communicate through digital interfaces
- ✓ Audio response for reconfirming main commands
- ✓ Easily expandable with additional measuring locations and sensors

Customer benefits

- ✓ Savings in raw materials and / or energy at the manufacturing stage
- ✓ Uninterrupted monitoring and logging of actual product quality
- ✓ Improvement in product quality, especially in conjunction with control
- ✓ Quick return on investment (ROI) and high profit potential

Measurements

- Basis Weight [g / m²] = radioactive source (Pm147, Kr85, Sr90)
- Basis Weight [g / m²] = X-ray Backscatter
- Moisture [% H₂O] = microwave or infrared
- Ash [%] = radioactive source FE55
- Coat weight [g / m²] = IR-reflection (direct) or Delta-weight (calculated)
- Gloss [DIN, ASTM...]
- Calliper [μm] = Laser Triangulation with distance and temperature compensation
- Calliper [μm] = slightly touching sensor by air cushion principle
- Colour / Opacity [d L*, d a*, d b*]
- Porosity [Bendtsen, Gurley, Coresta]
- Formation [Fa, Fq, Fdq...]

Traversing Platforms

- O-Frame Scanners
- Single sided scanners
- C-Frame Scanners

Operator Stations

- Stand Alone
- Desktop
- Integrated into Line Operator Station

Controls and Actuators

- Mahlo® Paper MD Control for Basis weight and Moisture
- CD Actuators for Slice and Dilution Control



PaperPro II scanning frame



KNOWLEDGE

We have a common goal: Maximum performance from your Mahlo® System. To that end we are at your side, right from the installation of the equipment and advice on how to maintain it, through to the training of your employees. Our instructors get your people in shape in matters of operating and servicing. So that you can solve your problems even faster.



UniScan M scanning frame



Mahlo® Qualicross: CD basis weight Profile Actuator for dilution water headbox systems.



TEXTILE



NONWOVENS



PAPER



PLASTIC

BASIS

VISUALIZATION

EVERYTHING AT A GLANCE

Product-highlights

- ✓ Simultaneous management of various sensors
- ✓ Freely scalable trend diagrams
- ✓ Selectable image scales for histograms
- ✓ Password protection: Unauthorised users are denied access to supervisor-selected screens
- ✓ Recipe management
- ✓ Integrated audio response

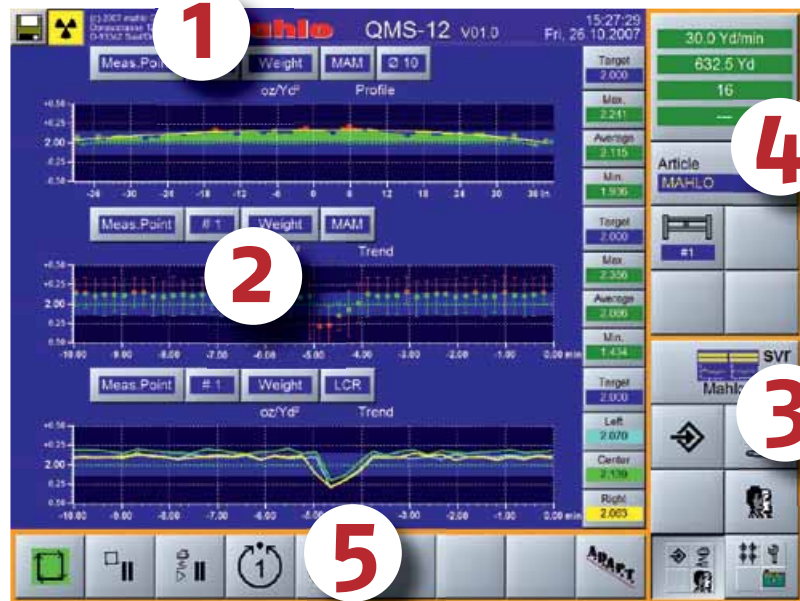

Main page

Customer benefits

- ✓ Menu guide in all common languages
- ✓ Ergonomic user prompting
- ✓ Easy to operate

The user interface consists of five areas:

1. Title line:

General information (including alarm bar)

2. Display area:

Selectable screen pages (display forms)

3. Selection block:

Navigation within the program

4. Vertical block:

Touch buttons for principal options

5. Horizontal block:

Touch buttons for basic functions and sub-options

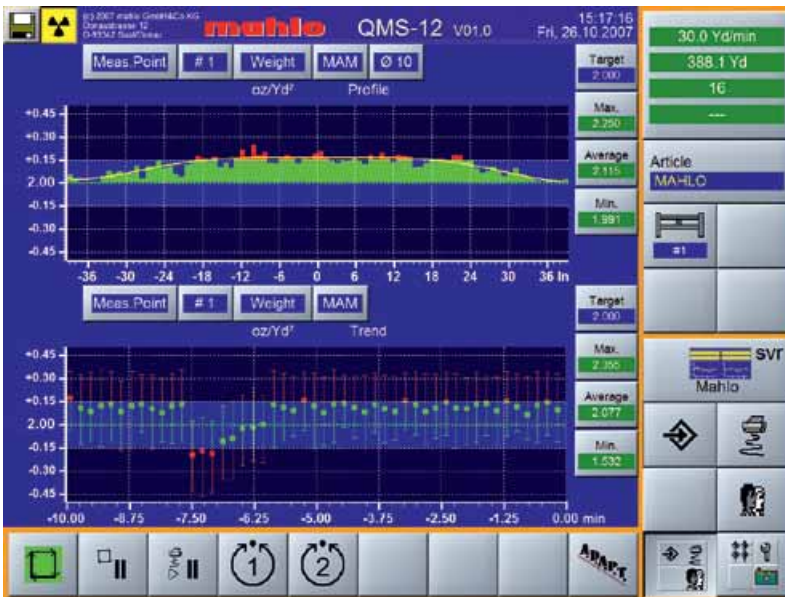

Main page indicating weight per unit area profile and trend



Operating menu for scanning frame

The use of rugged industrial touchscreen technology eliminates mechanical elements such as keys and switches. Everything is entered directly via the screen through large, ergonomic buttons. Audio response in the user's own language represents a huge leap in user-friendliness. Operation of the user-interface is easy and intuitive. All essential information is visible at a glance.



TEXTILE



NONWOVENS



PAPER



PLASTIC

MAHLO® QUALISCAN®

PAPERPRO II SCANNING FRAMES

The reliable and cost effective scanning platform with the most advanced sensor technology for continuous online measurement in the pulp & paper industry

Customer benefits

- ✓ Easy to install and connect
- ✓ A minimum of upkeep and maintenance costs, along with high availability and long service life
- ✓ The ultra-precise carriage-guide mechanism guarantees really accurate measurements from the various sensors
- ✓ Accident-proof thanks to the continuous monitoring of motor current and integrated safety cutout

Product-highlights

- ✓ Intelligent scanning frame with integrated real-time computer
- ✓ Extremely rugged, mechanical construction assures trouble-free operation and long service life
- ✓ Maintenance-friendly design
- ✓ Available in several versions, tailored for the specific application
- ✓ Constructed with commonly available standard components to ensure optimum availability of replacement parts

The Mahlo® Qualiscan® type scanning frames are the result of more than 25 years experience in building scanning platforms for continuous, high precision measurements on paper, board and pulp webs. These scanners are designed to meet the highest German engineering standards, aiming for unparalleled performance in combination with minimal cost of ownership. To ensure an unrivalled long life when being used under the very demanding conditions in the pulp & paper industries, only the highest quality components are being used.



PaperPro II scanning frame

Principle of operation

A frequency-controlled AC gearmotor drives via a shaft one or two vertically arranged drive belts (one each top and bottom). These are fixed to the scanners' platform-type carriages, which in turn are attached laterally or diagonally to the supports and which can be traversed on accurately pre-adjusted precision profile rails and bearings. As the scanner traverses the moving web, it provides a cross-machine direction profile of basis weight, thickness or moisture on the display console that is a cross-section of the manufactured product. The scanning width can be predetermined in recipe, or the the product edges can be automatically tracked by the standard edge detectors to eliminate any effects of web wander.

Since the measurement-related data supplied by the sensors is processed immediately by a real-time computer in the traversing frame, it can be transferred to the central control computer via an easy-to-run network cable.

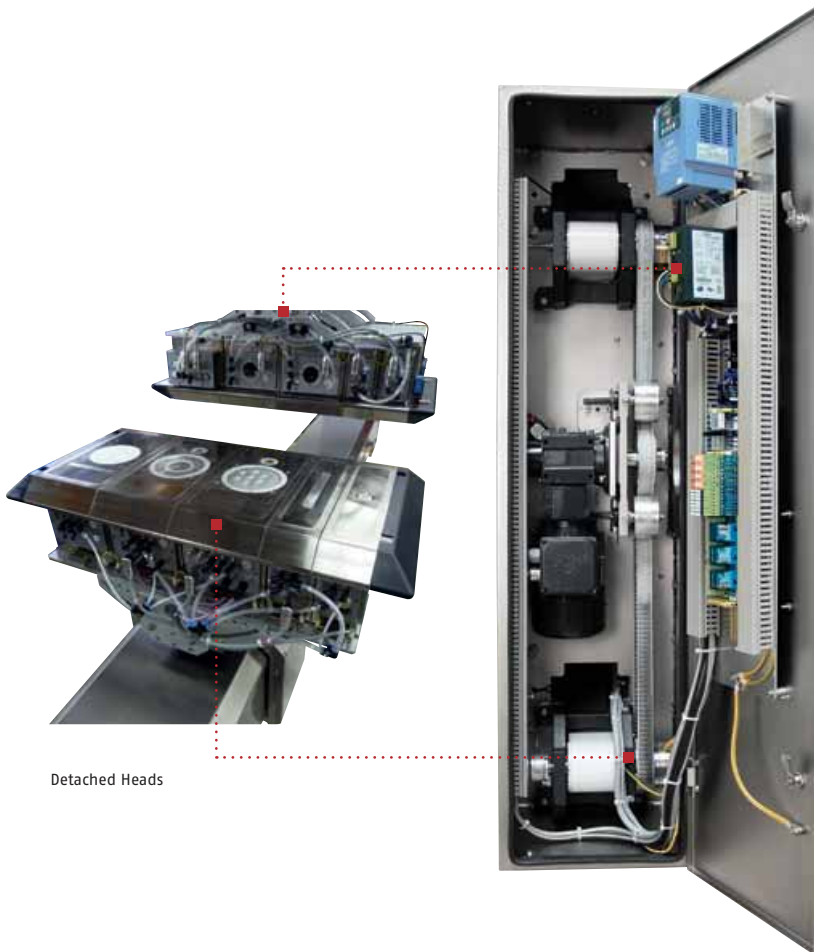

Detached Heads

Electromagnetical clutches for fast measurement head detaching



Low maintenance and cost of ownership

To keep the maintenance costs at a minimum, all Mahlo® scanners use standard, commercially available components. This is to comply with the requests of most customers for "open architecture" systems today, rather than creating "black boxes" which are only maintainable with direct support from the initial vendor.



TEXTILE



NONWOVENS



PAPER



PLASTIC

MAHLO® QUALISCAN®

PAPERPRO II SCANNING FRAMES

Design features

- Supports up to five sensors heads
- Adjustable pass line angle, $\pm 35^\circ$
- Heavy duty, maintenance free AC gear motor, driving two standard 4-inch (100 mm) steel reinforced head transport belts, by means of a KEVLAR® reinforced timing belt for perfect synchronicity of upper and lower measurement head assemblies
- Drive belts are matched for highest scanning accuracy
- Prepared for water cooling of all measurement heads and sensors, for use in environmental conditions of up to 105 °C (recommended: closed loop cooling circuit)
- Prepared for air purging, for use in very dusty environments (e.g. Tissue Paper)
- Integrated Safety Switches for maximum operator safety



Operational Benefits

- Rigid frame construction, utilizing precision treated rectangular steel beams, for precise measurement
- Central lubrication point
- Chromium plated, corrosion proof high precision linear bearings from THK®, with central greasing access for easy maintenance and unrivalled long life
- Electromagnetic clutches for fast measurement head detaching, for improved maintenance access
- Fast Detachable Stainless Steel Covers, for improved maintenance access
- Easy to install, all connections done by a simple RJ 45 Ethernet cable



Adjustable passline angle, $\pm 35^\circ$



Scanner



High precision linear bearings



Central lubrication



Removable side covers

SENSORS



TEXTILE



NONWOVENS



PAPER



PLASTIC

GRAVIMAT DFI

BASIS WEIGHT (MASS PER UNIT AREA) / THICKNESS

Applications

The Mahlo® DFI (Dynamic Flutter Independent) beta sensor uses a revolutionary new sensing technique that allows:

- Complete insensitivity to web flutter throughout the entire measurement gap.
- The smallest beta sources and the highest measurement performance.
- Very fast scanning speeds with ultra-narrow web defect detection.
- Long-term trouble free, cost effective operation in the harshest environments.

Virtually all web processes have problems with maintaining consistent flatness. Cast, extruded and calendered film and sheet exhibit ripples and flutter due to line tension changes, static electricity or in-line vibration. Paper and coating converters must deal with baggy substrates, edge curl and distances of unsupported web. Nonwovens and textile manufacturers see variations in the loft, density and thickness of their webs which result in center of mass changes.

All of these conditions result in measurement errors with traditional transmission sensors like X-ray or beta gauges. Backscatter sensors like gamma or X-ray are even more sensitive to web movement and some are even required to contact the web!

The new Mahlo® patented DFI Beta Sensor is not affected by web flutter, passline change, ripples, sag or edge curl. The DFI measures accurately throughout changes in loft, density or thickness.

Principle of operation

The Mahlo® DFI uses a multiple detector technique that captures the full measurement signal regardless of where the web is within the gap. The resulting measurement is determined only by the basis weight, not by the position of the web in the measurement gap. This solution is quite simple and industrially rugged, but it is completely effective. So effective in fact, that Mahlo® has been awarded international patents for the DFI.

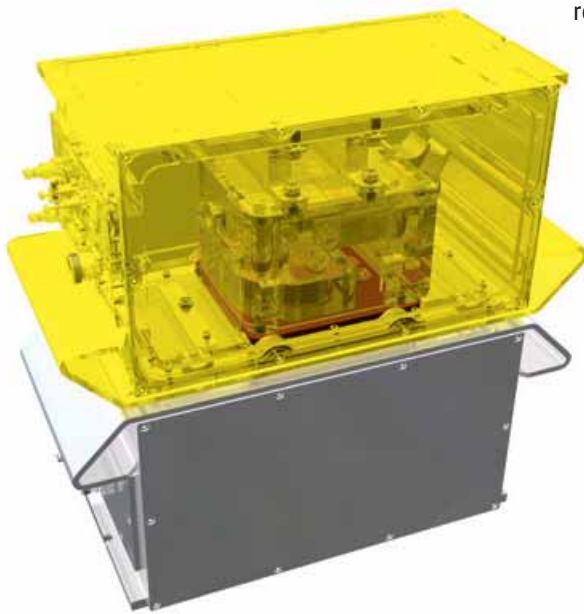

Product-highlights

- ✓ Intelligent sensor with ultra-fast microprocessor for pre-processing measurements
- ✓ Precise measurements as a result of using extremely efficient beta radiation detectors
- ✓ Four temperature-compensation sensors along with air pressure compensation
- ✓ Robust, sturdy emitter housing meets the most stringent safety regulations
- ✓ Variable measuring gaps to suit customer requirements

No heavy absorbers or highly radioactive sources are necessary. Mahlo® supplies its Kr85 DFI with only 260 mCi or smaller sources, yet the accuracy, speed and resolution of the Mahlo® DFI are the best yet offered.

An additional advantage of the Mahlo® DFI is that measurement gaps can now be substantially increased without worrying about additional web movement. Soft, easily damaged webs, or wet coatings no longer need to run the risk of contacting the sensor due to a narrow gap. The Kr85 DFI can use measurement gaps of 2 inches and more while measuring even light weight webs!

Principle of operation, unaffected by web position

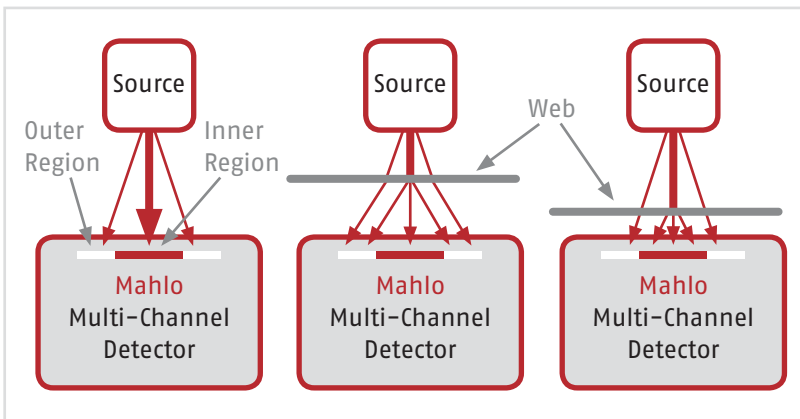

Gravimat DFI sensor response curve

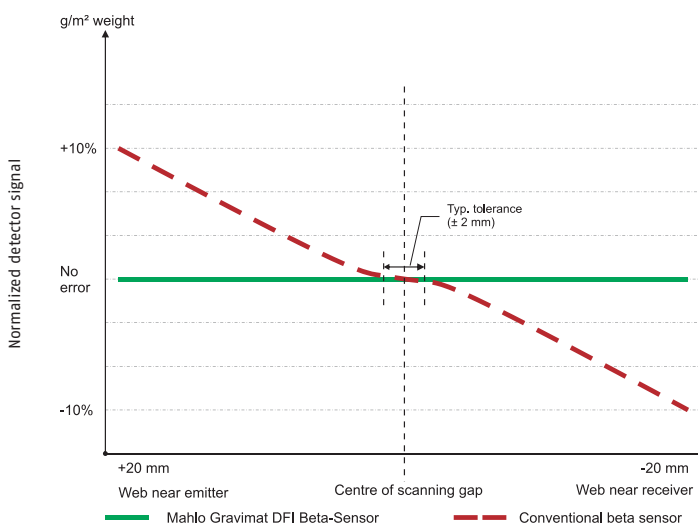

RELIABILITY

Our components do exactly what we build them for: hour after hour, year after year. Our design team ensures that the central nervous system of our equipment always works without interruption. So that you always reach your objective.

Customer benefits

- ✓ Non-destructive, continuous determination of the weight per unit area of product webs
- ✓ Highly stable and accurate measurement along with a minimum need to calibrate
- ✓ The DFI allows wider measurement gaps and avoids damage to soft webs or wet coatings
- ✓ Wide measuring range through use of various isotopes

SENSORS



TEXTILE



NONWOVENS



PAPER



PLASTIC

ASHPRO FMA

Measuring the ash content

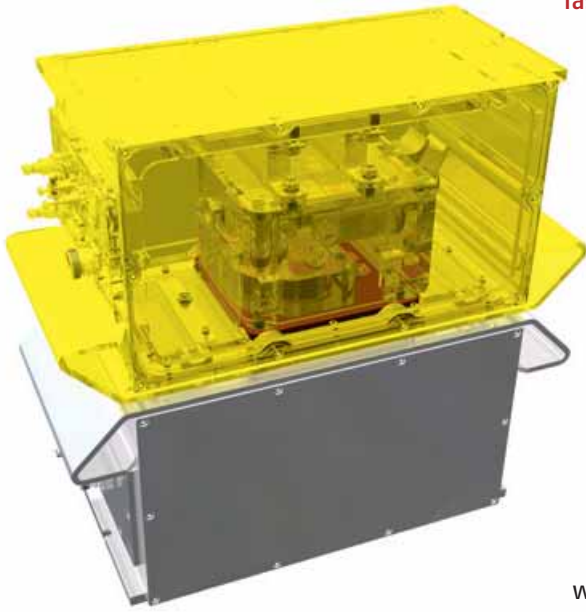

Tasks

The large number of different and highly specialised products in the paper and paper processing industry requires modern analysis processes to ensure consistent product quality. From tea bags and pulp to copying paper and up to heavy cardboard – there is a vast variety of materials for which the exact ash content needs to be determined in production.

Solution

The exact determination of the ash content is made possible through a sensor combination of Gravimat DFI and Ashpro FMA. The Gravimat DFI determines the grammage of the paper web – regardless of its fillers. The Ashpro FMA measures the reduction of the emitted radiation as it passes through the product web. This reduction is primarily caused by the fillers. The total ash content can be determined through reference to the grammage of the product.

Benefit

The ash content is a common expression for the paper components (inorganic fillers and pigments) that remain unaltered when cellulose is burned. For example, these are calcium carbonate, kaolin or titanium oxide. They affect important properties of the paper such as transparency, whiteness, dye absorption or coating. These properties and thus the quality of the product can be controlled by changing the ash content. Observing the max. ash content is also of fundamental importance with paper manufacturing using recycled paper. Furthermore, exceeding specific upper limits of the ash content causes increasing losses of fibre and results in higher disposal costs.

Can be used in

– Qualiscan® QMS-12

Product-highlights

- ✓ Contactless determination of the ash content and the grammage
- ✓ Intelligent sensor with fast microprocessor for measurement pre-processing
- ✓ Variable measuring gap geometry for different customer requirements



The ash content plays a major role in all segments of the paper industry.



Utilizing the Ashpro FMA in paper manufacturing with large proportions of sugarcane fibres.

Customer benefits

- ✓ Preventing increased fibre losses
- ✓ Optimising the disposal costs
- ✓ Optimising and control of the product quality
- ✓ Long life expectancy through the use of high-quality components
- ✓ Broad measuring range

SENSORS



TEXTILE



NONWOVENS



PAPER



PLASTIC

GRAVIMAT FMX

WEIGHT PER UNIT AREA

Applications

The Gravimat FMX sensor consists of a compact X-ray tube and its high-voltage power supply as well as special, modern X-ray detectors with the electronics for data acquisition. It is completely insensitive to environmental effects such as temperature and relative humidity. This new measuring principle is used with the proven Mahlo® components for data recording and processing, and is therefore fully compatible with other products of the Qualiscan® QMS family.

The manner in which X-rays interact with mass allows for the measurement of a very wide range of web basis weights using a single sensor, from 50–20,000 g/m² with the web against a steel roller or in free air!



Product-highlights

- ✓ Single-sided measurement requiring a minimum of space; easy to integrate into existing systems
- ✓ Measuring device works with an X-ray tube that can be turned off, and has no radioactive isotope emitter
- ✓ Insensitive to distance-related variations due to patented detection system
- ✓ It can measure against a steel roller, thereby ensuring perfect web guiding at the measuring point
- ✓ Virtually insensitive to the chemical composition of the web thanks to 65 KV tube

GRAVIMAT FMX in place



Principle of operation

The photons from an X-ray tube are directed towards the product, from which they are partially backscattered. The backscattered photons generate a high number of pulses in the detectors, thus enabling precise and ultra-stable measurement of the weight of the web.

The detector signal generated by the X-ray backscatter increases linearly with the weight of the product. Errors traditionally associated with web position, flutter or temperature are eliminated by the sensor design. When the density is known, the thickness of the material can also be determined very accurately (film, PVC, etc.).

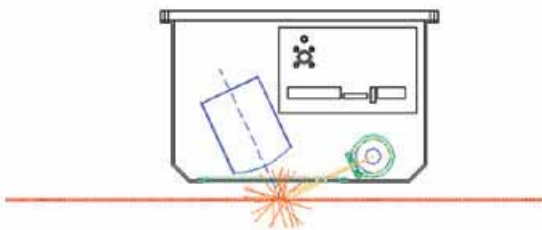

Principle of operation, schematic representation

Customer benefits

- ✓ Can be installed without having to modify the processing range and existing web guiding arrangement
- ✓ Easy to certify, and a minimum of radiation safety requirements; X-rays can be turned off
- ✓ Highly accurate and virtually insensitive to product composition
- ✓ Extremely wide measuring range using the same instrument without modification or redesign

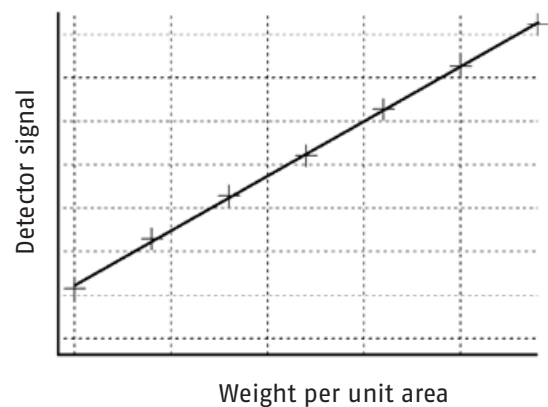

Gravimat FMX measurement diagram

SENSORS



TEXTILE



NONWOVENS



PAPER



PLASTIC

AQUALOT HMF

MOISTURE MEASUREMENT

Applications

Product moisture is an extremely important parameter for the manufacturer and processor of web products such as paper, textiles, cardboard and nonwovens. Microwave-absorption technology has been used for quite some time to determine this quantity online, but up to now, limited resolution has restricted its use to measurement of larger quantities of water, thus preventing it from being used to measure thinner products or lower levels of moisture. With this patented measuring technique it is possible to detect even the smallest amounts of water exceedingly accurately and with a high degree of stability, thereby enabling it to be used on even thin printing paper, airbag materials or the nonwovens used in the hygiene sector, without its accuracy being affected by product colour or composition.



Sensor model DS-20

Product-highlights

- ✓ Highly accurate and stable measurement thanks to microwave-resonance analysis
- ✓ Unaffected by the color of the product web or its chemical composition
- ✓ Temperature compensation by using a pyrometer to detect product temperature
- ✓ Servo-motor controlled tracking of the lower resonance chamber in traversing mode (sensor model DS-115)

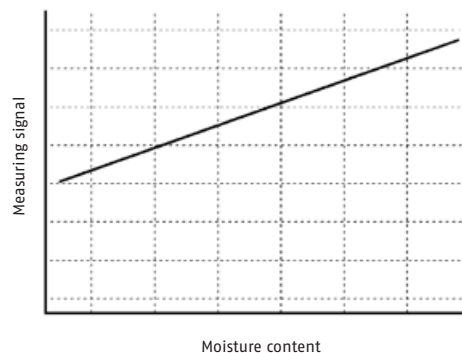

Principle of operation

The sensor consists of two parts, which together form a resonance chamber, and the product passes through the centre of this divided chamber. A microwave emitter stimulates two standing waves in the resonance chamber, whereby one of the two corresponds to the absorption wavelength of the water molecules in the microwave spectrum and the second serves as a reference. Contrary to the traditional absorption technique, the Aqualot HMF device evaluates the shift in the resonant frequency of the two standing waves with respect to each other rather than the attenuation of the microwaves by the quantity of water molecules in the measuring gap. This patented "microwave resonance" principle is virtually insensitive to changes in product composition, an advantage that helps keep the number of product-specific calibrations to a minimum. In addition, the device is characterised by its ability to resolve to an exceedingly high degree even the lowest percentages of moisture, thereby extending the use of microwave technology significantly in comparison with traditional measuring techniques.

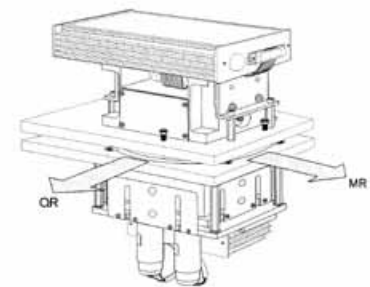

Automatic scanner centring

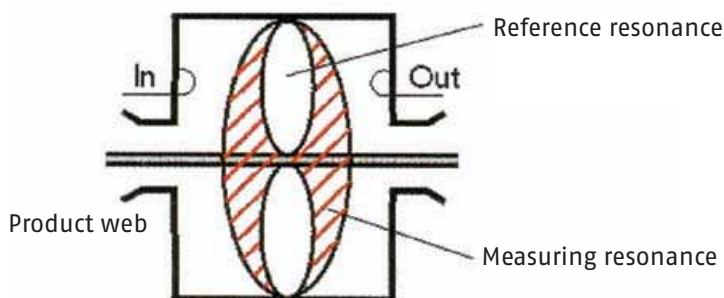

Principle of measurement

Customer benefits

- ✓ Non-destructive, continuous determination of the amount of moisture (H₂O) in product webs
- ✓ Extremely accurate and stable measurements; calibration reduced to a minimum
- ✓ Long life expectancy through the use of high-quality components
- ✓ Wide measuring range through the use of various resonance configurations

SENSORS



TEXTILE



NONWOVENS



PAPER



PLASTIC

INFRALOT IMF

MOISTURE AND ORGANIC COMPOUND MEASUREMENT

Applications

By optically analysing reflected light energy in the near-infrared range (NIR), the Mahlo® IMF sensor can measure online, non-destructively and without adversely affecting the product's characteristics important product-specific parameters such as moisture (water), coating weight, the thickness of plastic film, or the organic components in nonwovens. The NIR backscatter sensors of the Infralot IMF series are based on the classic 6-filter measuring principle, but are updated with the very latest optical components and in accordance with the most recent trends in optical measuring technology.

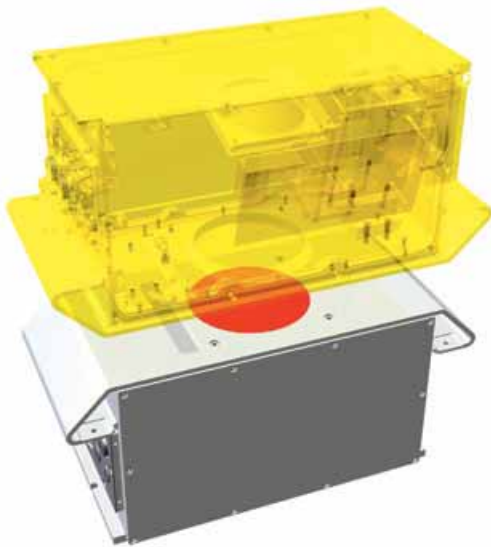

Product-highlights

- ✓ Beam generation by means of a robust halogen lamp
- ✓ High-speed filter wheel with six optional filters
- ✓ Easy to install, non-critical with respect to product distance and impurities
- ✓ Can be calibrated by the customer by means of a simple gauging tile
- ✓ Detectors cooled by an integrated, regulated Peltier element
- ✓ Easy access to the measuring optics for cleaning purposes

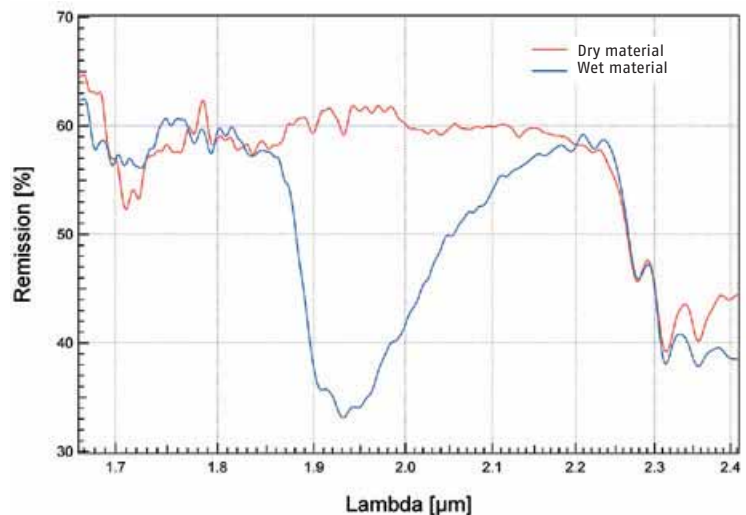

Infralot IMF diagram

Principle of operation

Light-specific wavelengths can induce the atomic bonds of certain molecules to oscillate at a multiple of their basic frequency, whereby the major portion of the incidental light energy is absorbed by the product. If the light reflected from a product is evaluated for its energy separately for each wavelength, a relationship between the degree of absorption of these resonant wavelengths and the number of absorbing molecules can be determined. The graph shows this clearly. Dependent on the amount of moisture in the product, the light energy absorbing alters significantly at the resonant wavelength of the water molecule. To obtain a stable measurement in practice, the reflected light energy at the resonant wavelength is compared with other non-absorptive wavelengths (references).



LISTENING

Our sales team knows how to listen: with our customers' individual requirements, wishes and ideas firmly in mind, they point our R&D engineers in the right direction. Consequently, you get exactly what you really need.

Customer benefits

- ✓ Non-destructive, continuous analysis of various web or sheet parameters
- ✓ Exceedingly accurate and stable measurements; calibration reduced to a minimum
- ✓ Long life expectancy through the use of high-quality components
- ✓ Wide range of applications by using various measuring wavelengths

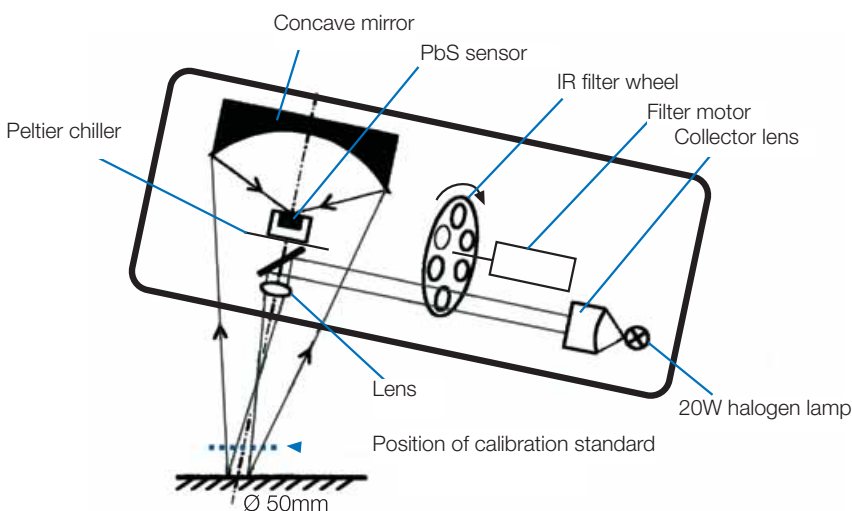

Schematic representation of the IMF measuring principle

SENSORS



TEXTILE



NONWOVENS



PAPER



PLASTIC

CALIPRO DML

NON-CONTACT THICKNESS GAUGE

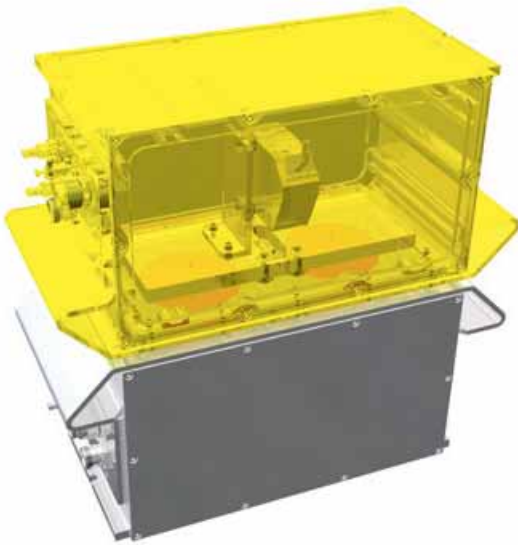

Applications

In principle, the two-sided, non-contact, laser-type thickness gauge can be used to monitor virtually any product in web or sheet form. Successful applications for this technique can be found in the paper and cardboard industry, nonwoven sector, plants manufacturing PVC flooring or other calendered or extruded plastic webs and sheets, and in the manufacture of artificial leather.

Product-highlights

- ✓ Non-contact, non-destructive and ultra-precise measurement online of product thickness
- ✓ Available in several configurations to suit various requirements in terms of accuracy
- ✓ Can gauge either at one side against a reference roller or on both sides
- ✓ A good number of optional measuring ranges with a single appliance
- ✓ High sampling rate and resolution of the cross-web profile

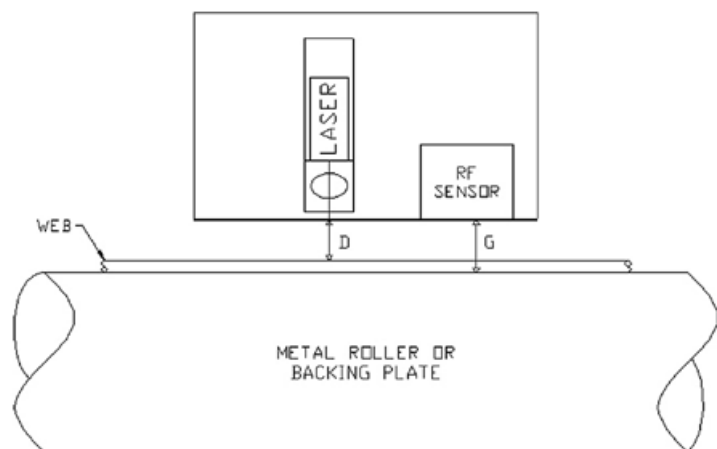

Calipro DML, single-sided version

Principle of operation

Either one or two laser-triangulation sensors determine the exact distance between the gauging sensor(s) and product surface, either from one or both sides. Depending on the arrangement, an additional sensor, usually a high-precision eddy-current sensor, determines either the distance between the two gauging sensors or distance between the one sensor and a reference roller.

The thickness of the product is then determined by evaluating the difference between the two measured values. This is done by the Calipro DML's built-in microprocessor, which at the same time synchronises the upper and lower lasers and, on the certain versions, processes in real-time the data measured by the numerous temperature sensors which compensate for any temperature-related dimensional changes in the housing.

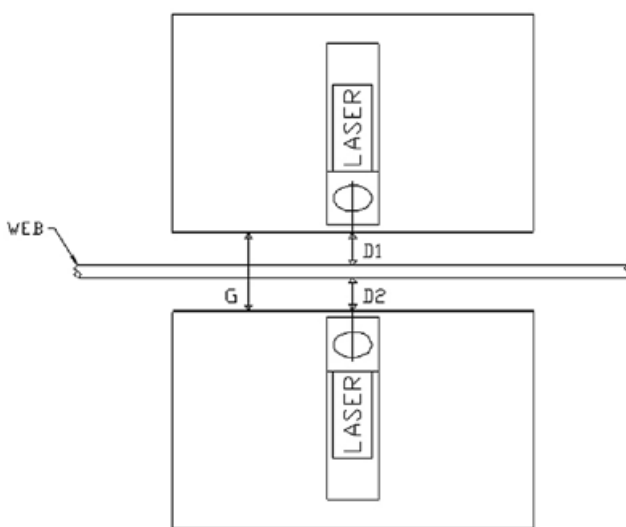

Calipro DML with two-sided laser sensor



PROMPT INSTALLATION

Our service team ensures that the installation of our equipment runs smoothly and on-time. So that your investment is turned quickly into profit.

Customer benefits

- ✓ Determines the thickness of a web or sheet directly without reference to product density
- ✓ Since the gauge is able to traverse, it indicates the thickness of the product from edge to edge
- ✓ Non-contact measurement has no adverse effect on either product quality or the manufacturing process
- ✓ Insensitive to variations in the surface of the product, hence a high degree of measurement-related stability

SENSORS



TEXTILE



NONWOVENS



PAPER



PLASTIC

CALIPRO DMP

CONTACT MEASUREMENT OF THICKNESS

Product-highlights

- ✓ Simple, non-destructive and high-precision determination online of product thickness
- ✓ Available in several forms for various measuring ranges
- ✓ On smooth running webs, measurement is virtually contact-free thanks to the air cushion

Applications

The air cushion principle lends itself especially for very slow running webs with a dense, close-textured surface. It is ideal for calendered, transparent film, on which the laser technique may struggle due to insufficient reflection of the laser beam from the surface of the film. The sensor can also be used to good effect on slow-running paper or cardboard sheet, provided that linespeed does not exceed 100 m/min.

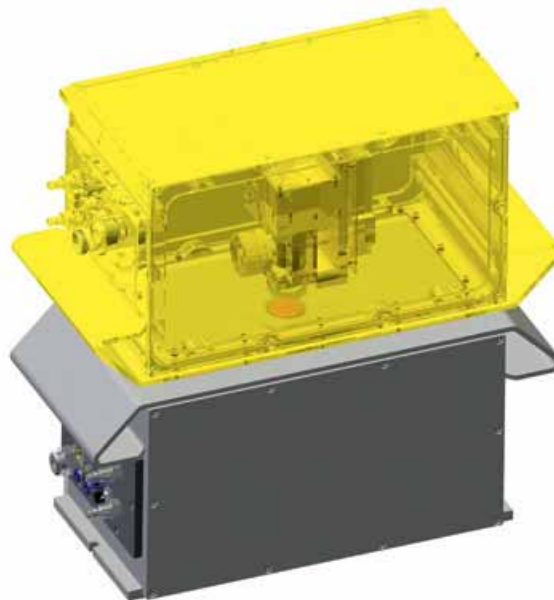

Principle of operation

Two plungers, one each above and below the web are gently pressed against it by a finely adjusted volume of compressed air. At the surface of the plungers, a precisely defined volume of air is emitted through finely bored holes. This forms an air cushion above and below the web so that the plungers virtually float over the surface of the online sheet.

In each of the two plungers is a coil, which together form an inductance. By varying the distance between the coils (ie. product thickness), the inductance changes, and by connecting a capacitor in series with them, the resonant frequency of the oscillator thus formed varies in accordance with the thickness of the product.

Customer benefits

- ✓ Determines the thickness of the product web directly
- ✓ Indicates the thickness of the web from one edge to the other
- ✓ Completely insensitive to variations in the surface of the product
- ✓ Can be used to gauge even highly transparent products, e.g. PET or PA film



Quality made
in Germany

For decades we have been developing and producing our machines exclusively in Germany – using the highly motivated specialists we have trained ourselves. This is your guarantee of the highest level of quality.

60¹⁹⁴⁵₂₀₀₅ YEARS
MAHLO

SENSORS



TEXTILE



NONWOVENS



PAPER



PLASTIC

GLOSSPRO GMR

GLOSS MONITOR – REFLECTION

Product-highlights

- ✓ Simple, non-destructive and exact determination online of surface gloss
- ✓ Available for various angles of reflection to meet the appropriate industrial standards

Applications

The device can be used in any industry where there is a need to determine the degree of surface gloss on a product, i.e. in the paper industry (SC paper, LWC, writing and printing paper, the film industry and in the furniture sheeting and impregnated paper sector).



Fundamentals

A pulsed LED white-light source is concentrated via an suitable lens onto the surface of the product web. The light reflected at the desired angle (60° or 75°) from the surface of the sheet is focused by a lens, and the intensity of this reflected light is determined by suitable detectors. To compensate for the effect of dust on the lenses and protective windows, a reference beam is also deflected via a similar light path and is directly evaluated. Since all lenses and windows are exposed to a very similar concentration of dust, any possible mismeasurements in the time between periodic cleanings are reliably offset.

Customer benefits

- ✓ Direct determination online of the degree of gloss quickly optimizes processing
- ✓ As the sensor traverses, it indicates the degree of gloss from edge to edge
- ✓ Largely insensitive to variations in product colour through using suitable detectors



INNOVATIONS

We love being technological leaders. And our R&D team works every day to make sure it remains so. Innovations, inventive talent and future-oriented thinking – to guarantee your success.

TECHNICAL DATA | PAPERPRO II

| Scanning frame | PaperPro II |
|-----------------------------|--|
| Scanner width | Web width: 800 – 6400 mm |
| Scanning speed | 30 – 500 mm/s |
| Sensor payload | Five sensors, both upper and lower carriages |
| X-, Y-, Z-axis runnout | X (scan axis [CD]), $\pm 300 \mu$ (± 0.3 mm) Y (machine axis [MD]), $\pm 100 \mu$ (± 0.1 mm) Z (vertical axis), $\pm 150 \mu$ (± 0.15 mm) |
| Scan location repeatability | $\pm 250 \mu$ (± 0.25 mm) |
| Operating temperature | |
| without cooling | 0 – 45 °C |
| with air cooling | 0 – 60 °C |
| with water cooling | 0 – 85 °C |
| Cooling scanning frame | Air purging with cooled compressed air |
| Cooling sensors | Scanner is plumbed as standard for compressed air or liquid cooling (some components optional) |
| Power | 230 VAC, 50 Hz or 115 VAC, 60 Hz (to be specified with order) |
| Interface | TCP / IP (Ethernet) |

TECHNICAL DATA | UNISCAN M

| Scanning frame | UniScan M |
|--|--|
| Scanner width | Web width: 800 – 6400 mm |
| Scanning speed | 30 – 300 mm / s |
| Sensor payload | Three sensors, mounted to the carriage |
| Scan location repeatability | $\pm 250 \mu$ (± 0.25 mm) |
| Operating temperature (without cooling) | 0 – 45 °C |
| Cooling scanning frame | Air purging with cooled compressed air |
| Cooling sensors | Scanner is plumbed as standard for compressed air or liquid cooling (some components optional) |
| Power | 230 VAC, 50 Hz or 115 VAC, 60 Hz (to be specified with order) |
| Interface | TCP / IP (Ethernet) |



DEVELOPMENT

To ensure high-performance capability and maximum customer benefit from our products, we rely on the latest technologies and maximum commitment to develop the products of tomorrow. So that the future can start for you today.

Dimensions

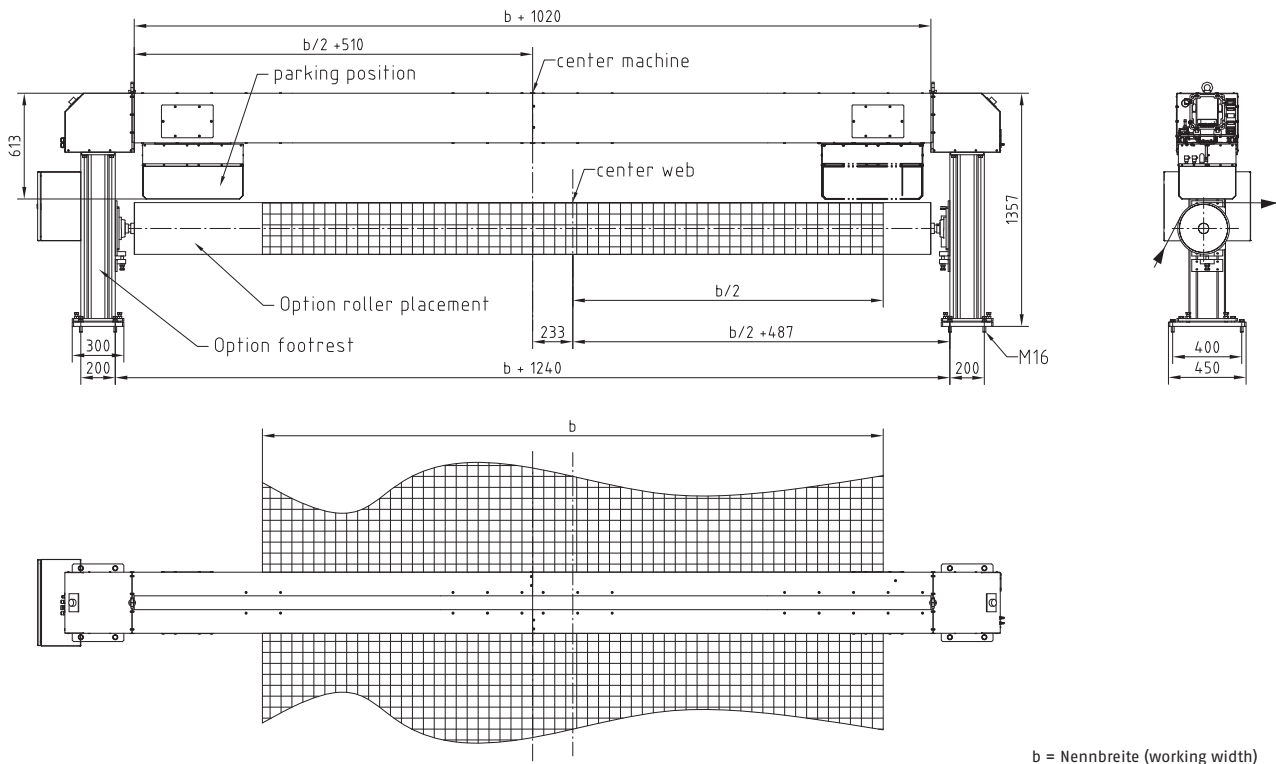

b = Nennbreite (working width)

Measuring frame UNISCAN M
for GRAVIMAT FMX sensor
91-013784

TECHNICAL DATA | GRAVIMAT DFI

| Sensor | Gravimat DFI | | |
|---|---|--|---|
| Isotope | Promethium-147 | Krypton-85 | Strontium-90 |
| Activity | 1000 mCi (37 GBq) | 260 mCi (9.6 GBq) or 80 mCi (2.9 GBq) | 20 mCi (750 mBq) |
| Range (basis weight) (grams / square meter) | 2.5 - 160 g / m ² | 10 - 1400 g / m ² | 100 - 5000 g / m ² |
| Repeatability (2 σ , 1 s) (the greater) | ± 0.05 % or ± 0.05 g / m ² | ± 0.1 % or ± 0.1 g / m ² (260 mCi: t = 4 s) | ± 0.3 % or ± 0.5 g / m ² |
| Measurement gap | 10 / 15 / 30 mm | 10 - 100 mm | 10 - 100 mm |
| Temperature compensation | At 4 locations (source and detector enclosures, measurement gap at source and detector faces) | | |
| Barometric compensation | Electronic, included in C&D console | | |
| Passline / flutter tolerance | 100 % of measurement gap from 10 - 40 mm (minimum of 2.4" within larger gaps) | | |
| A/D conversion resolution | 16 bit (1/65536 FS) | | |
| Power supply | 24 V DC | | |
| Maximum ambient conditions | Max. 60 °C, 0 - 95 % relative humidity (non-condensing) higher temperature applications upon request | | |
| Maximum current useage | Source max. 1 A (continuous: 0.5 A) | Detector max. 2 A (continuous: 0.3 A) | |

TECHNICAL DATA | ASHPRO FMA

| Sensor | Ashpro FMA |
|--------------------------|--|
| Measuring principle | Absorption of X-ray radiation |
| Measuring gap height | 10 - 30 mm |
| Power supply | 24 V DC |
| Max. ambient temperature | 60 °C, 0 - 95 % relative humidity (non-condensing) |

Dimensions

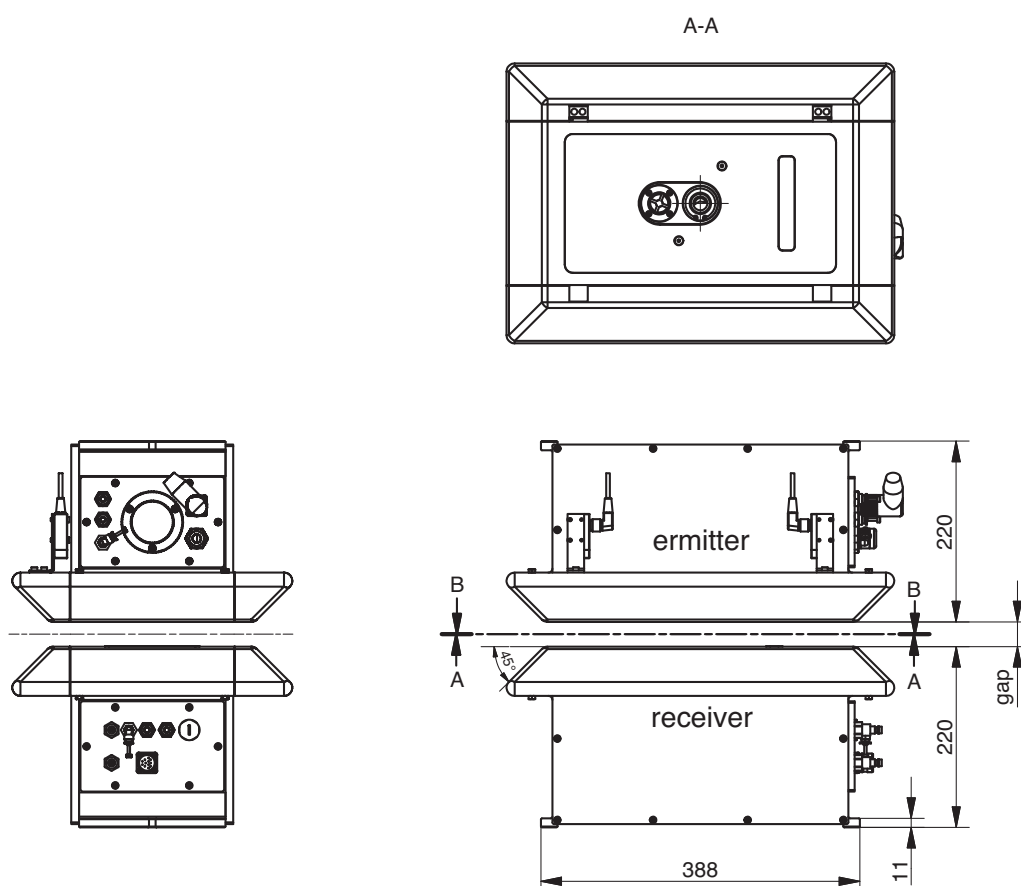

ASHPRO FMA
91-015583

SERVICE AND SUPPORT

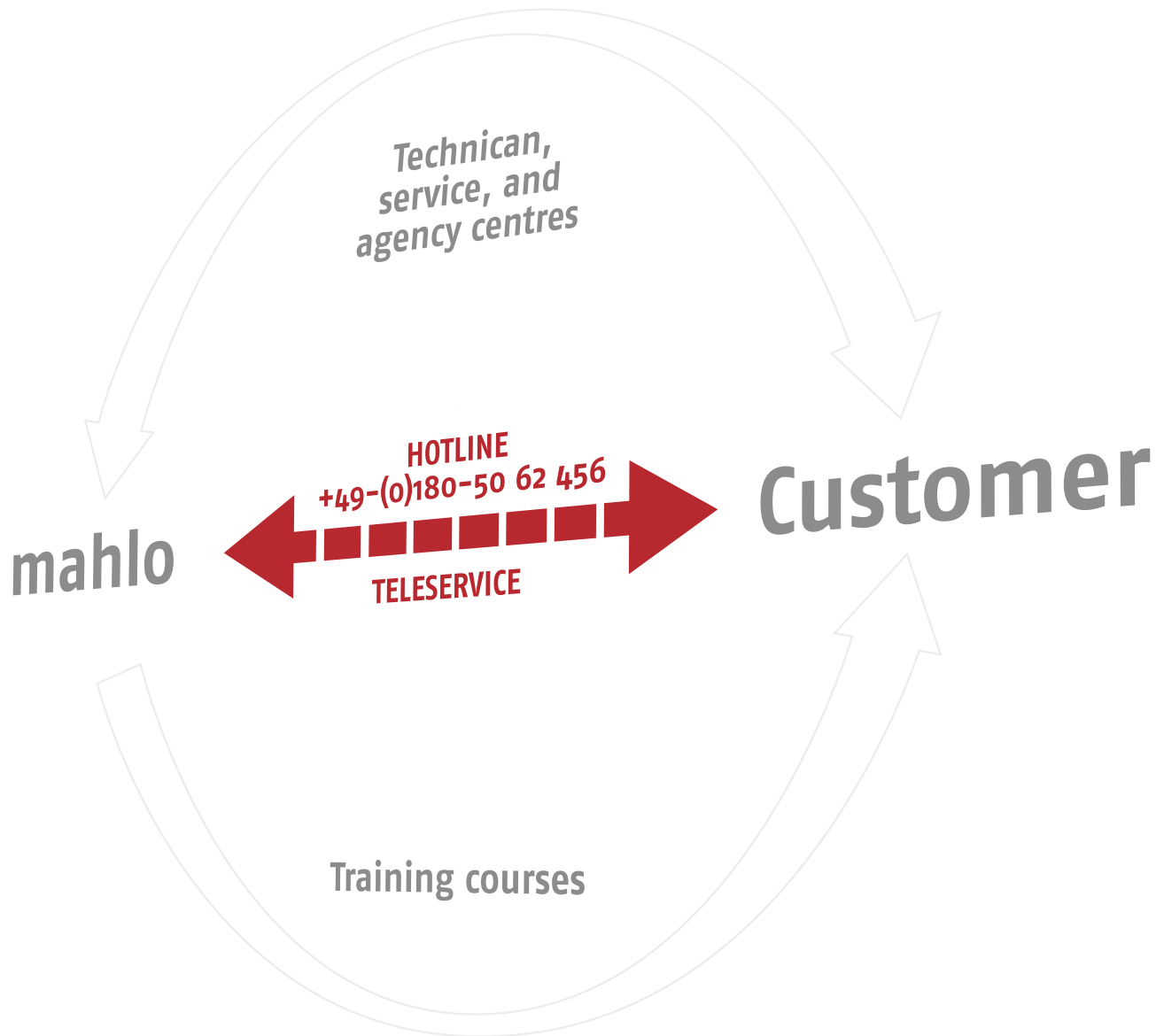

Mahlo® has for decades been setting standards in the field of measuring and control systems for the textile industry: using innovative and trend-setting technology.

In addition to technology, direct contact with our customers is especially important to us. This includes intensive assistance and customer care wherever the customer is located, a global service and agency network and our 24-hour replacement part service.

We wish to convey to you the good feeling and security of being able to count on the know-how of our experts in any situation, regardless of whether it concerns installation and start-up, conversion of existing systems or the servicing of your appliances.

TECHNICAL DATA | GRAVIMAT FMX

| Sensor | Gravimat FMX |
|-------------------------|---|
| Measurement | X-ray backscatter sensor |
| Beam generator | X-ray tube |
| Measuring range | 50 – 20000 g/m ² |
| Accuracy | ± 0.4 g/m ² at 100 g/m ² ± 1.0 g/m ² at 500 g/m ² ± 2.5 g/m ² at 2000 g/m ² |
| Distance sensor-product | 15 – 50 mm (standard 20 mm) |
| Distinctive feature | Can measure against a steel roller or free air |
| Cooling | Water (circulation) |
| Power supply | 24 V DC |
| Ambient limits | Max. 60 °C, 0 – 95 % relative humidity (higher temperature applications upon request) |

Dimensions

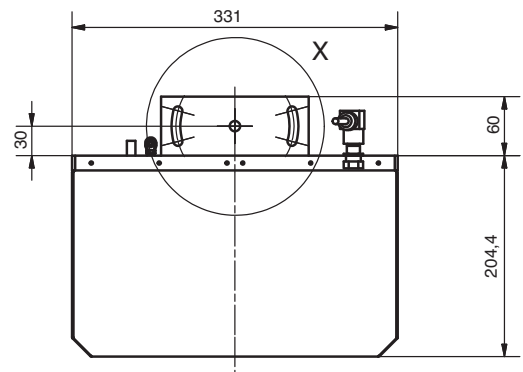
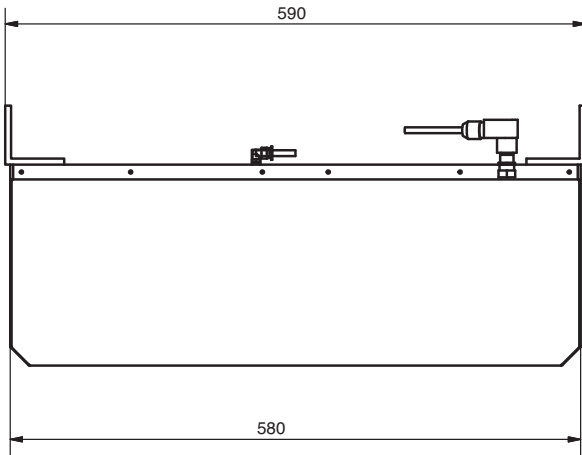

GRAVIMAT FMX sensor
91-013782

X (1 : 2)

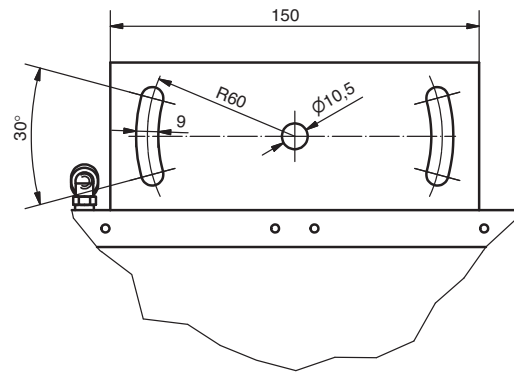

TECHNICAL DATA | AQUALOT HMF

| Sensor | Aqualot HMF | | | |
|-----------------------|---|-------------------------|--------------------------|--------------------------|
| Measurement Principle | Microwave resonance | | | |
| Model | DS-115 | | DS-20 | |
| Measurement range | 1 | 2 | 3 | |
| Water weight | 1 - 25 g/m ² | 1 - 50 g/m ² | 1 - 100 g/m ² | 1 - 600 g/m ² |
| Resolution | ± 0.01 g/m ² | ± 0.02 g/m ² | ± 0.04 g/m ² | ± 0.1 g/m ² |
| Measurement Gap | 10 mm | | 13 mm | |
| Power supply | 24 V DC | | | |
| Operation limits | Max. 70 °C (or higher with water cooling) | | | |



CONTINUANCE

Our decades of experience has made us the reliable partner which we are today. Independent, determined and forward-thinking. So that we can also be here for you tomorrow.

Dimensions

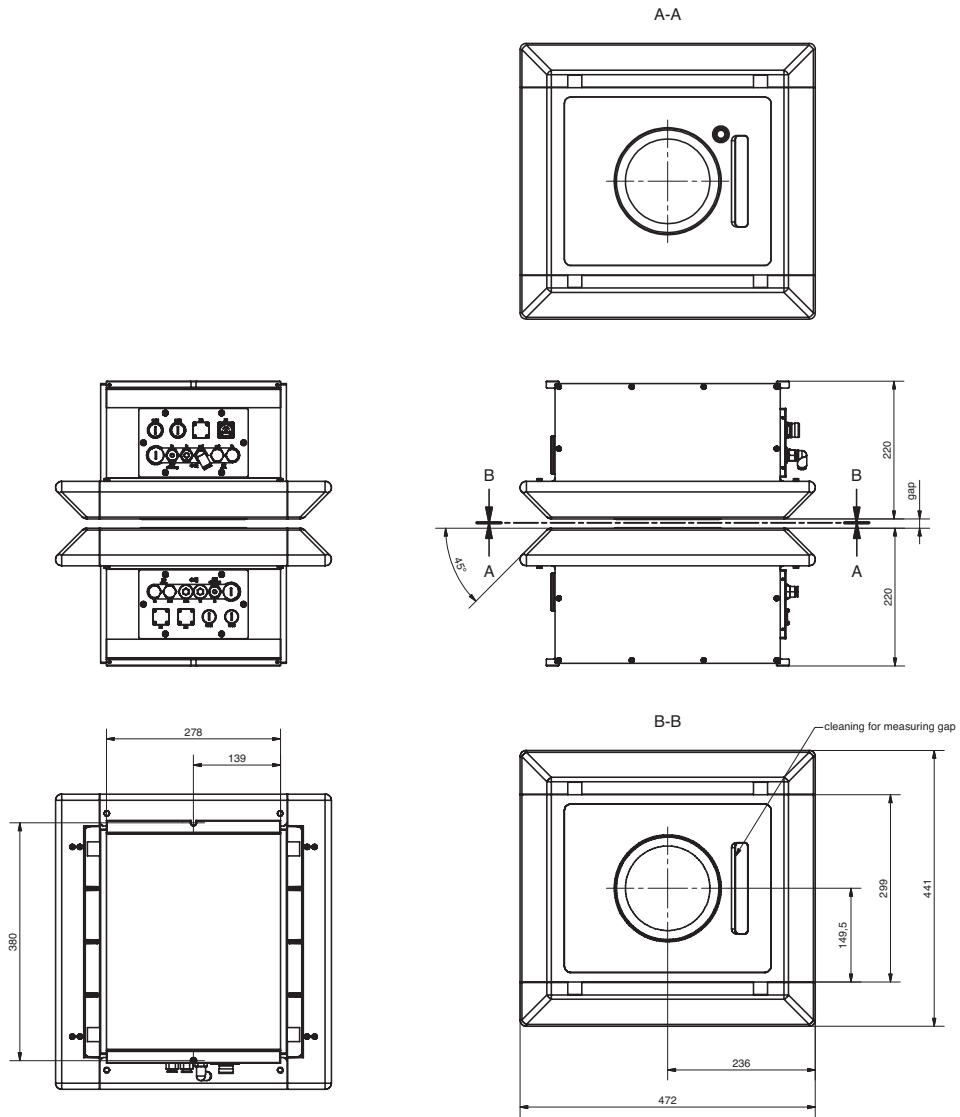

Aqualot HMF sensor
91-015875

TECHNICAL DATA | INFRALOT IMF

| Sensor | Infralot IMF |
|--------------------------|--|
| Measurement | Near infrared backscatter sensor |
| Wavelength band filter | 1820 – 2320 nm |
| Measuring range | Moisture: 0.1 – 95 % absolute Coating weight: 0.5 – 500 g/m ² Organic constituents: 2 – 1000 g/m ² |
| Distance to product | 10 – 100 mm |
| Scanning spot diam. | > 30 mm (dependent on the distance) |
| Life of lamp | 2 years (on average) |
| Scan duration (internal) | 25 ms |
| Power supply | 230 V |
| Ambient limits | Max. 60 °C, 0 – 95 % relative humidity (non-condensing) |



AROUND THE CLOCK

We know every nut and bolt on our machines. Your replacement part will be on its way to you within 24 hours. We set everything in motion. Just so that you don't stand still.

Online-Support:

SERVICE@MAHLO.COM

Support-Hotline:

+49-(0)180-50 62 456

Dimensions

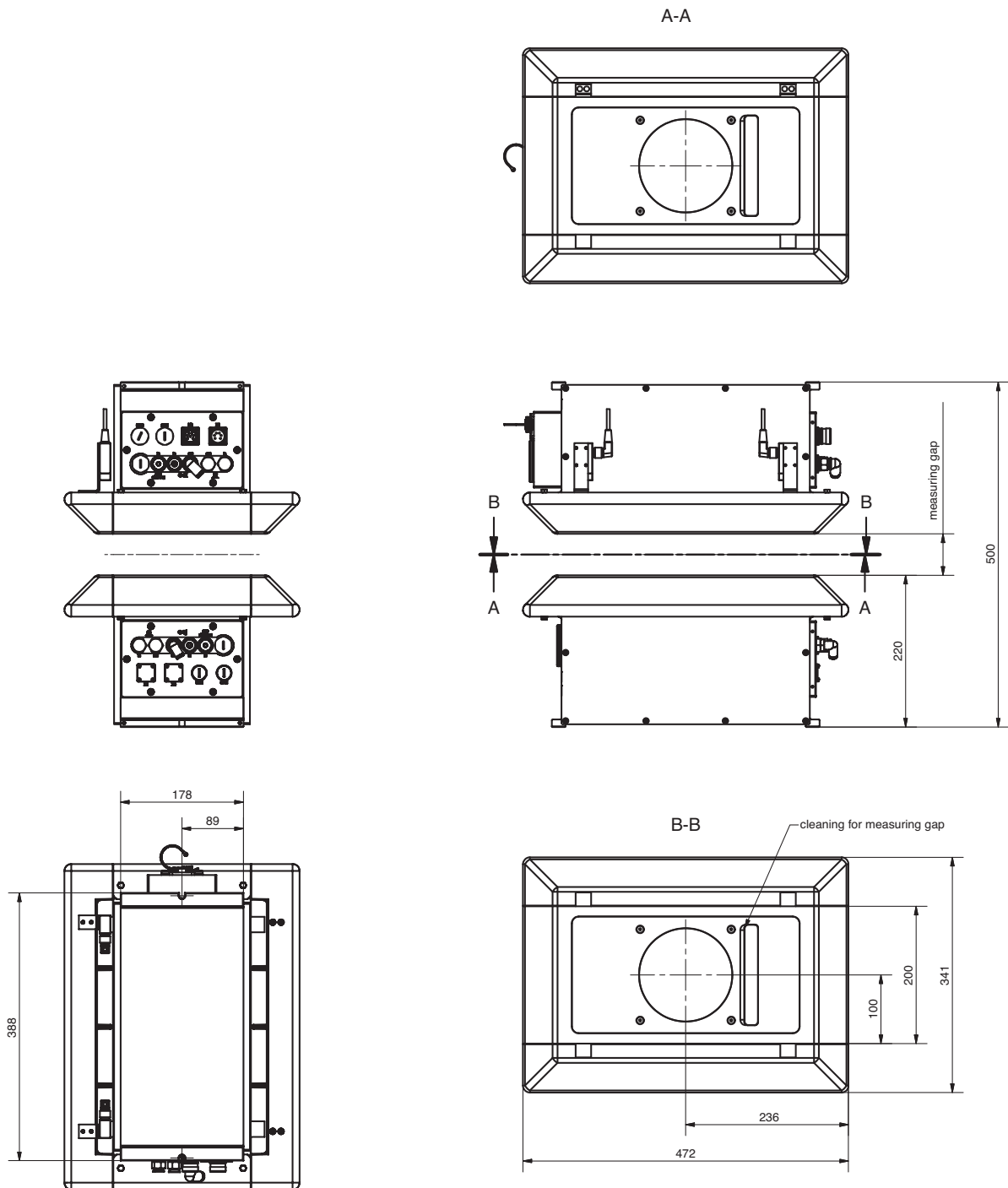

INFRALOT IMF sensor
91-015851

TECHNICAL DATA | CALIPRO DML

| Sensor | Calipro DML | |
|---------------------------|---|--|
| Configuration | Type 1, with distance compensation | |
| | Double sided | Single sided |
| Measurement Principle | Laser-Triangulation, one sensor on top and bottom | Laser-Triangulation, against precision reference roller |
| Measuring range | 0 - 18 mm | 0 - 18 mm |
| Measurement gap | 18 mm | 18 mm |
| Radial run-out offset | High precision HF sensor | High precision HF sensor |
| Wavelength range | 650 nm | |
| A/D conversion resolution | 16-Bit (1/65536 FS) | |
| Power supply | 24 V DC | |
| Ambient limits | Max. 60 °C, 0 - 95 % relative humidity (non-condensing) | |
| Options | Air purging Air- or water cooling Stainless steel housing | |

Dimensions

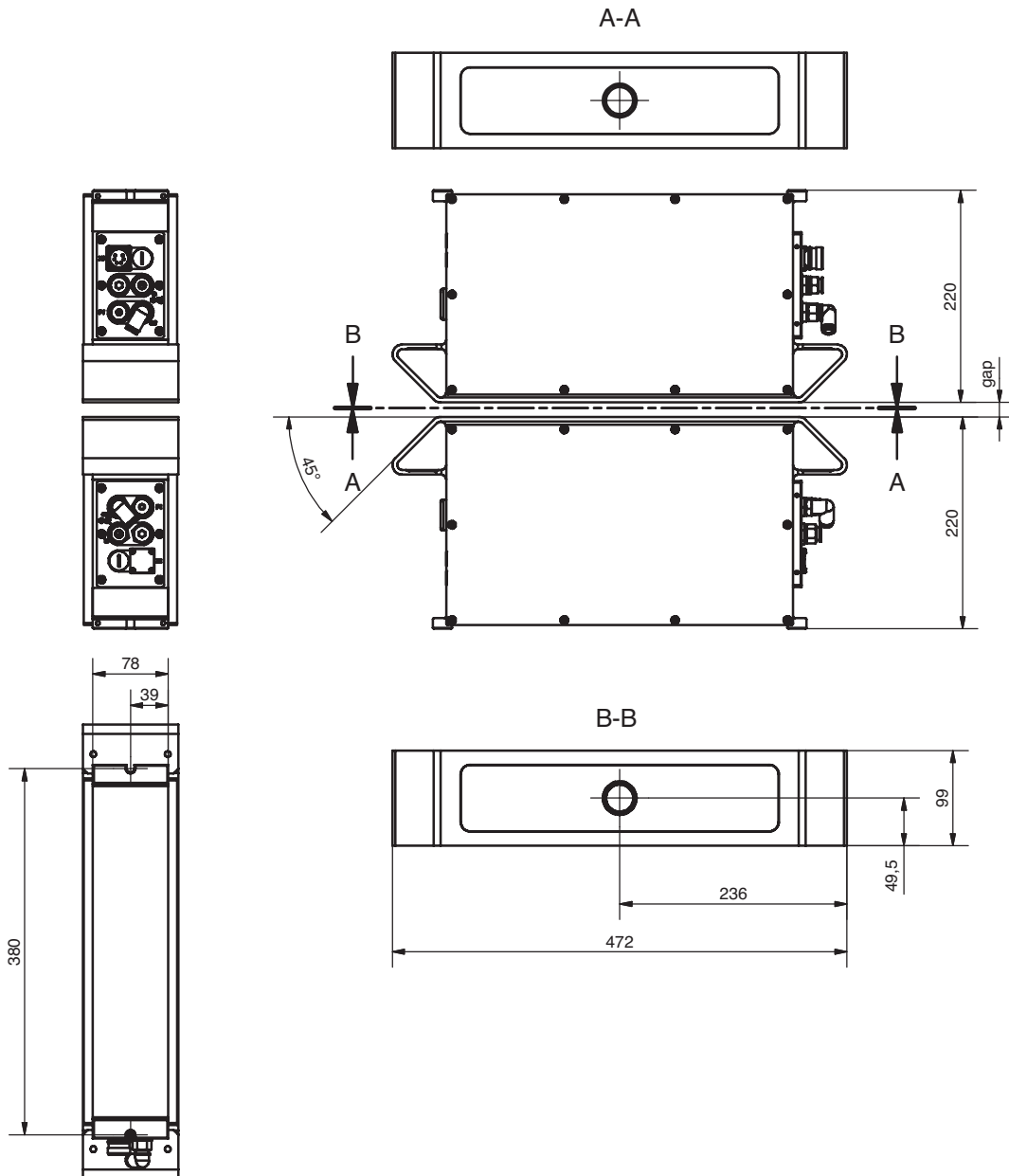

CALIPRO DML sensor
91-015876

TECHNICAL DATA | CALIPRO DMP

| Sensor | Calipro DMP | |
|--------------------------|---|---|
| Configuration | Type 1, double sided, small range | Type 2, double sided, large range |
| Measurement principle | Measurement piston with air cushion, one sensor on top and bottom | Measurement piston with air cushion, one sensor on top and bottom |
| Measurement range | 0 - 1000 μ | 0 - 2500 μ |
| Measurement gap | 20 mm | 20 mm |
| Scanner compensation | Software correction | Software correction |
| Air supply | 2 bar, instrument air (oil- and waterfree) | |
| A/D-converter resolution | 16-Bit (1/65536 FS) | |
| Power supply | 24 V DC | |
| Limits | Max. 60 °C, 0 - 95 % relative humidity (non-condensing) | |
| Options | Air purging Air- or water cooling Stainless steel housing | |

Dimensions

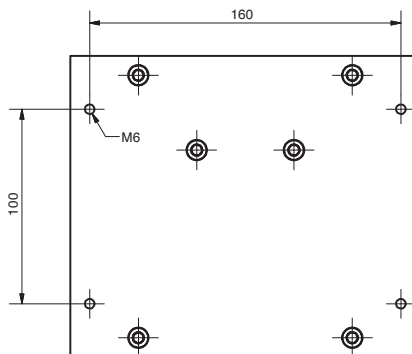
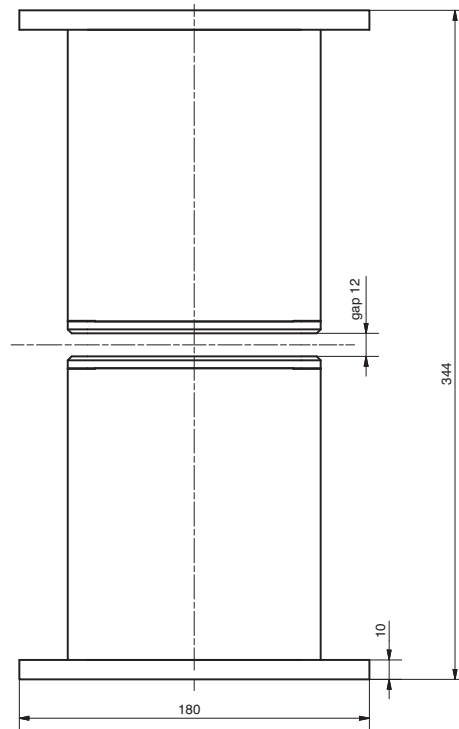
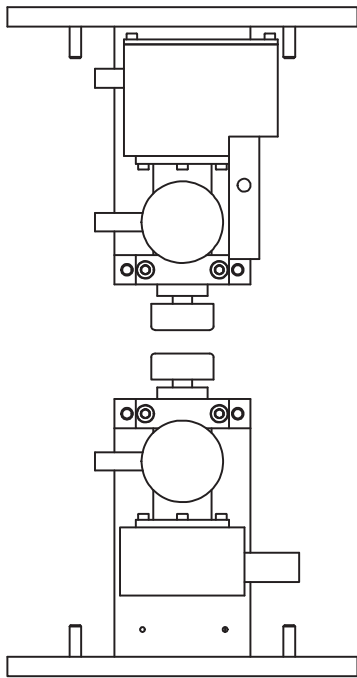

CALIPRO DMP sensor
91-200757

TECHNICAL DATA | GLOSSPRO GMR

| Sensor | Glosspro GMR | |
|--------------------------|---|--|
| Measurement | Gloss backscatter sensor | |
| Wavelength band | 400 – 800 nm | |
| Measuring range | Gloss, 60 ° Gloss, 75 ° | 10 – 95 % absolute 10 – 95 % absolute |
| Distance to product | 15 mm | |
| Scanning spot diam. | Oval, 5 x 10 mm | |
| Life of lamp | Lifelong, as it is a white-light LED | |
| Test duration (internal) | 5 ms | |
| Power supply | 24 V DC | |
| Ambient limits | Max. 60 °C, 0 – 95 % relative humidity (non-condensing) | |



FIRST AID

You can count on our service team, especially when "first-aid" is required. A call is all it takes to get our technicians on-site. Around the clock – and around the globe. So that you can concentrate on your work without having to worry.



Online-Support:

SERVICE@MAHLO.COM

Support-Hotline:

+49-(0)180-50 62 456

Dimensions

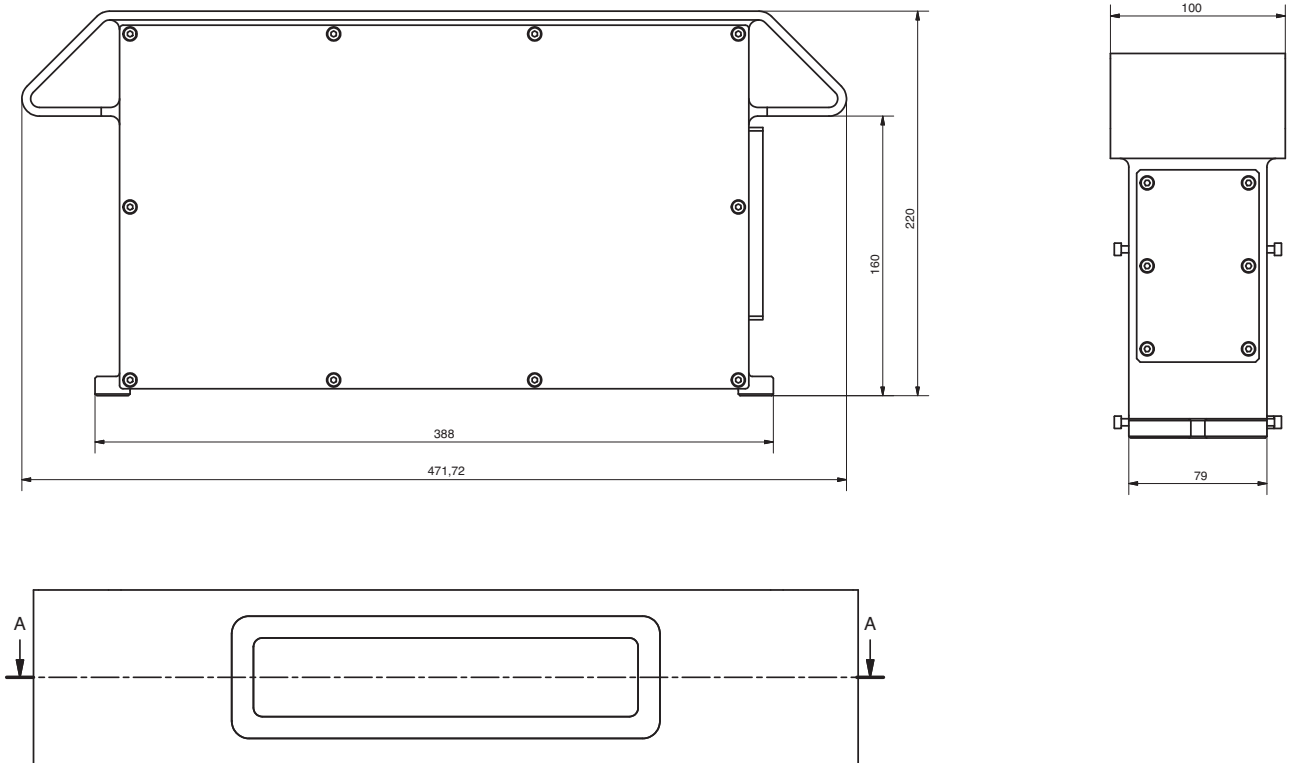

GLOSSPRO GMR sensor
91-201529

Monitoring and control systems, automation:

MAHLO® GUARANTEES QUALITY. WORLDWIDE, IN YOUR VICINITY.

Best-possible technical support and transfer of know-how are written in capital letters at Mahlo®. Thanks to an international network of agencies and service centres, customers have at their disposal competent support worldwide. We are there for you 365 days a year, 24 hours a day. Just get in touch with us!

- ✓ Over 40 service centres worldwide
- ✓ Prompt service and supply of spare parts within 24 hours
- ✓ Remote diagnostic system
- ✓ Service-hotline: +49-180-5062456



Overall management of Mahlo GmbH + Co. KG
and all subsidiary companies:
Ralf Hopp, Dipl.-Ing. (FH)

Mahlo GmbH + Co. KG Germany

Donaustr. 12, 93342 Saal/Donau
Contact: Ralf Hopp
Tel.: +49-9441-601-0
Fax: +49-9441-601-102
info@mahlo.com

Mahlo Italia S.R.L. Italy

Via Fiume 62, 21020 Daverio
Contact: Michel Bruni
Tel.: +39-0332-94-95-58
Fax: +39-0332-94-85-86
mahlo.italia@mahlo.com

Mahlo America Inc. USA

P.O. Box 2825, Spartanburg, S.C. 29304
Contact: Alan Lavore
Tel.: +1-864-576-62-88
Fax: +1-864-576-00-09
mahlo.america@mahlo.com

Mahlo España S.L. Spain

C/ Santa Margarida, s/n - Nave nº13
Poligono Industrial Riera de Caldes - Boada Vell
E08184 Palau Solità i Plegamans (Barcelona)
Contact: Jordi Grass
Tel.: +34-90-20062-30
Fax: +34-90-20062-40
mahlo.espana@mahlo.com

Mahlo Ouest S.P.R.L. Belgium

Quartum Center
Hütte 79 - Bte 10
4700 Eupen
Contact: Manfred Havenith
Tel.: +32-87-59-69-00
Fax: +32-87-59-69-09
mahlo.ouest@mahlo.com

Mahlo de Mexico SA de CV. Mexico

Av. del Iman 580, Edif. La Joya, Depto. 304,
Col. Pedregal de Carrasco, Del. Coyoacán D.F., CP 04700
Contact: Jordi Grass
Tel.: +52-555-606-47-52
Fax: +52-555-606-47-52
mahlo.mexico@mahlo.com

WWW.MAHLO.COM



Quality made
in Germany

60 YEARS
1945
2005
MAHLO

