

WEBSCAN WIS-12

Online product inspection system





TEXTILE



NONWOVENS



PAPER



PLASTIC

WEBSCAN WIS-12

A modular system designed for inspecting material, detecting and logging faults and irregularities across the full width of the product.

Range of application

The Webscan WIS can be used in practically every industrial sector where products are manufactured or finished (e.g. coated) in web form. Since its component parts are constructed and assembled in modular form, it can be tailored to meet the specific requirements of individual customers. The already well-proven areas of application range from the textile manufacturing sector, to the coating and textile finishing industries, through to the manufacture of nonwovens. The standards of quality of these up-market materials require an efficient and 100 % reliable examination of the web surfaces.

Basic features

Aided by the very latest in high-tech cameras, a Webscan WIS inspection system checks the online product for faults. The system is provided as per requirements with several line scan cameras to enable it to evaluate extra-wide material as well. In doing so, it discriminates between various types of defects. The standard system is capable of detecting faults at line-speeds of up to 120 m/min (or, on request, higher if required).

To avoid the adverse effect of extraneous light, the material can be illuminated by either incident or penetrative back light with diffuser discs in a panelled enclosure. Various kinds of light and colour can be chosen to suit the application.

The software package of a Webscan WIS inspection system is tailored to meet each customer's requirements. It provides continuous online visualization of the running web, data-logging as per specifications and classification of faults. It features in addition numerous ways

Product-highlights

- ✓ Modular assembly
- ✓ Detection at high line-speeds
- ✓ The very latest high-tech line cameras
- ✓ Comprehensive operating software with corresponding visualization



MEET THE NEED

Modular. Flexible. Scaleable.

The well thought out modular concept enables the system to be customised exactly to your individual requirements. From budget-priced hole detection up to the smart high-end inspection system – all variants are possible. Therefore, you will only pay for what you really need.

and means of involving the acquired data in other processing stages (by displaying the check results on an inspection table or cutting machine).

In addition to that, Mahlo® offers turnkey installations comprising a centre wind unrolling frame, online colour monitor Colorscan CIS, fault detector Webscan WIS, inspection table and centre wind / tangential batcher with ultrasonic sensors to calculate moment and diameter.



Webscan WIS-12 and colour monitor Colorscan CIS-12 at the back-end of a washing range + dryer (by kind permission of Schoeller Textiles AG, Switzerland).

Customer benefits

- ✓ 100 % product inspection
- ✓ Fault detection with corresponding classification
- ✓ Comprehensive data-logging

CONTENTS

WEBCAN

Components	4
Modular assembly	
Visualization	8
Everything at a glance	
Examples	10
Range of application and uses	
Project course of events	14
Customer care from A-Z	

TECHNICAL DATA

All technical data from page	15
------------------------------	----

WEBSCAN



TEXTILE



NONWOVENS



PAPER



PLASTIC

COMPONENTS

MODULAR DESIGN

Modular. Flexible. Scaleable

Difficulties do not stick to rules – there are no standard problems. That is why there are no standardised solutions, too. Each problem in your production process is unique and requires an optimally tailored solution that exactly addresses your individual requirements. Off-the-shelf solutions cannot accomplish that. Depending on your application, their capabilities are either insufficient or oversized and, therefore, far too expensive.

Webscan WIS's consistently modular architecture has solutions for all the conceivable requirements. Modularity allows the system to be scaled in any way, in turn optimally tailored to your production environment.

Depending on the application, product width, and speed, the following can be varied:

- Number of measuring bridges (camera bridge and associated lighting)
- Number of cameras and camera type (depending on the resolution)
- Resolution (depends on the fault types and classes)
- Lighting (incident light, transmitted light with fluorescent lamps or LEDs, etc.)
- Light colour (white, red, IR, or UV)
- Computing power required
- Type of installation (open, in-line, or encapsulated system)

Thanks to its flexible design, Webscan WIS can be optimally integrated into work processes. These mainly include logging and finishing.

Logging has three objectives:

- Documentation of the production process
- Control of finishing (trim optimisation, cutting, and packaging) by the logged data
- Create a data basis that can be used to optimise the production process



TEXTILE



NONWOVENS

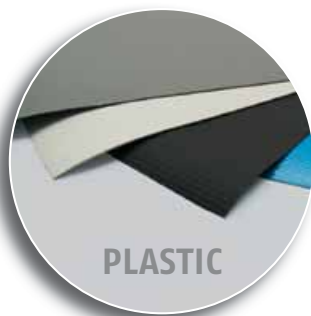

PLASTIC

Modular design

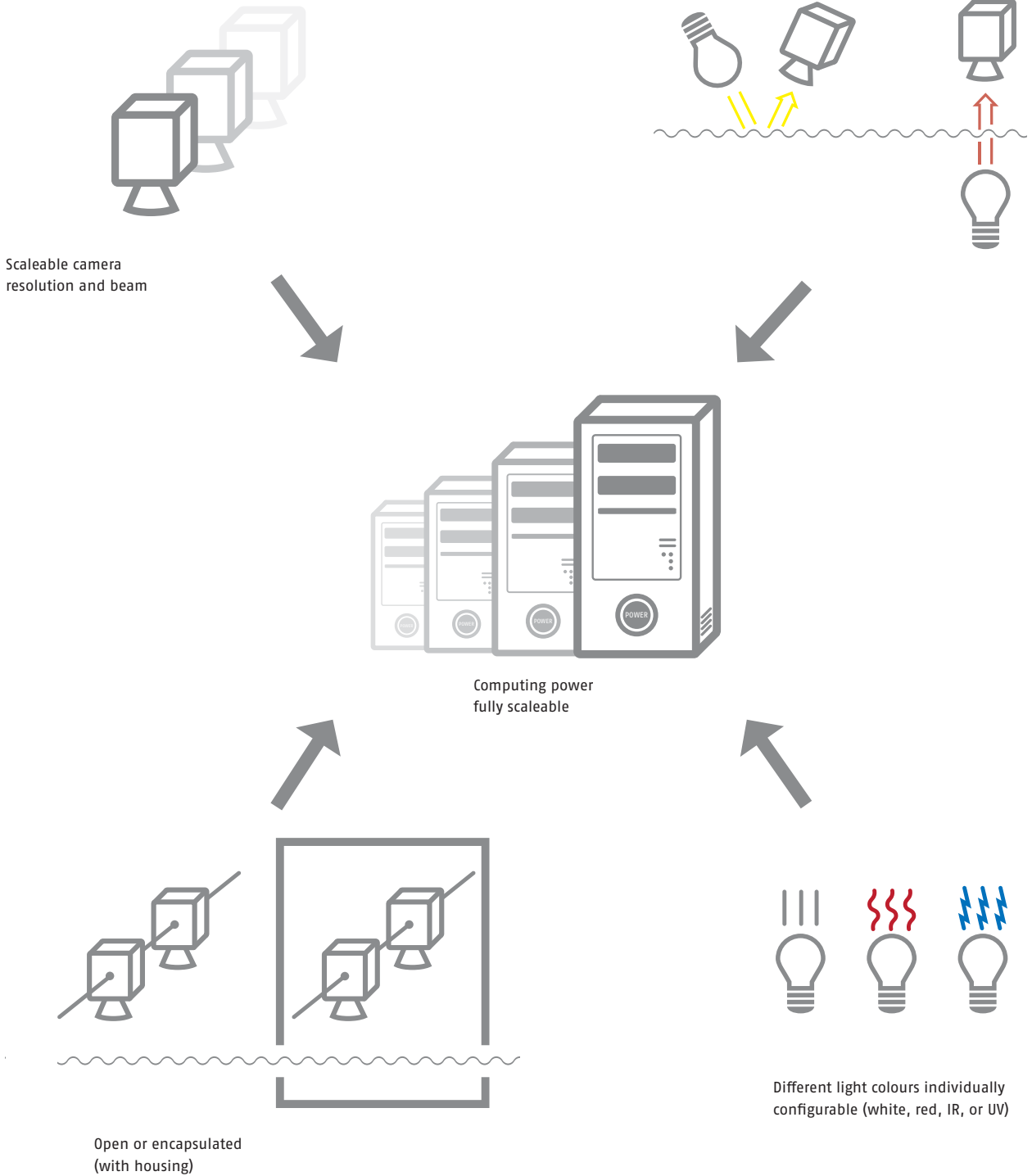



TEXTILE



NONWOVENS



PAPER



PLASTIC

WEBCAN

COMPONENTS

MODULAR ASSEMBLY



Various lighting units are available for use in any given situation.



The number of camera modules is adapted to the given requirements.

Lighting

In accord with the application and purpose, various lighting options can be used, although it is imperative to see that the product is uniformly and well-lit from edge to edge.

Dependent on requirements, a Webscan WIS works with the following optional kinds of lighting and colour:

- back lighting
- incident light
- LED
- fluorescent
- white, red, IR, UV

Cameras

Being a modular system, a Webscan WIS can be fitted with multiple high resolution line scan cameras to enable it to inspect both standard width and extra-wide products. The camera system from Mahlo® processes the data acquired for visualization in 256 shades of grey.

Marking

Faults can be marked automatically as per customer requirements by a colour marker, label printer or ink-jet printer. By doing so, any defective places on the product can be easily located again.



RELIABILITY

Our components do exactly what we build them for: hour after hour, year after year. Our design team ensures that the central nervous system of our equipment always works without interruption. So that you always reach your objective.

Software

In addition to the optics and individual hardware components, the system software is tailored to our customers' needs and specifications. The modular construction of the Webscan WIS ensures that, irrespective of the field of application and target objectives, it will perform as well as it possibly can for our customers. In doing so, product line-speed, lighting, width and classification are amongst other things of paramount importance. Consequently, Webscan's software provides not only an assurance of 100 % detection of faults but also the ways and means of adapting the system to the widest possible variety of manufacturing stages and line-speeds.

The system software's distinctive features are:

- control via touch screen
- recipe management
- fault recognition and classification
- selvedge detection
- automatic adjustment of light intensity
- integrated data bank
- integrated voice module
- digital I/O interface for alignment control
- data bank interface (ODBC)
- interface for acquisition of production data (OPC)
- remote diagnostics
- marking
- module for display of inspection results
e.g. on a perching table or cutting machine

Data logging

In addition to the numerous ways and means of visualizing the faults detected by a Webscan WIS, the latter provides a customer-specific logging facility. The data from each inspection cycle is deposited in a data bank and can be retrieved in the form of a print out as per specifications. This holds on record every fault and associated image.



Numerous software options allow precise analysis of each fault.



Analysis and logs in various formats are available

WEBCAN

VISUALIZATION

EVERYTHING AT A GLANCE



TEXTILE



NONWOVENS



PAPER



PLASTIC

Product-highlights

- ✓ Clearly arranged fault display
- ✓ High resolution detection of faults from 0.25 mm in size
- ✓ Precise logging in PDF-format
- ✓ Password protection: access to the program is denied to unauthorized persons
- ✓ Integrated audio response

Customer benefits

- ✓ Continuous inspection, classification and logging
- ✓ Storable recipes for various types of product
- ✓ Menu prompt in all the usual languages
- ✓ Ergonomic user prompt
- ✓ Easy to operate



Fault display

The user-interface is split into five sections:

1. Title bar:

General information (incl. alarm bar)

2. Display options block:

Selectable screen pages (display forms)

3. Selector block:

Navigation inside the program

4. Vertical block:

Touch buttons for main options

5. Horizontal block:

Touch buttons for basic functions and sub-options



Detailed image



Live image

A Webscan WIS can depict each fault individually. This presents an opportunity to analyse the primary cause of the defect, so that suitable measures can be adopted at previous processing stages.

The faults are classified automatically into:
(other classifications can be included on request)

- spots / flecks
- lengthwise defects
- widthwise faults
- selvedge defects
- seams

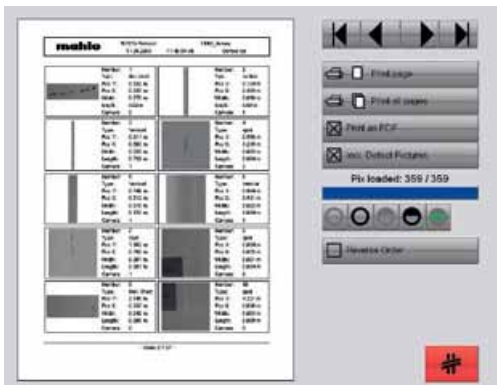

Typical data log

Continuous inspection and logging are two of the key tasks associated with quality control. The complete, clearly arranged log provided by a Webscan WIS can be printed out in PDF form or issued in XML format for subsequent processing.

The use of touch screen technology supersedes control elements (push-buttons and switches). All input is entered directly via generously sized, ergonomic touch pads on the screen. Audio response in the user's or other optional language enhances considerably user-friendliness. Control via touch screen is simple and intuitive. All essential information is screened instantly.



Detailed image lengthwise fault



Detailed image spot fault

WEBSCAN



TEXTILE



NONWOVENS



PAPER



PLASTIC

EXAMPLES

APPLICATIONS

Here, the typical applications of Webscan WIS are shown. They range from small systems to complex high-end systems. However, these are only examples – the actual systems will always be optimally tailored to your individual requirements and individually configured. Product speeds from 80 up to 200 m/min are possible depending on the required resolution and the type of defects to be detected.

Example 1: Hole detection

- one measuring bridge with two cameras
- one lighting device

The name says it all. One measuring bridge with two cameras covering the product width scans the product's top side. A transmitted light device is installed on the underside. This enables you to reliably detect even the smallest holes, such as catalytic defects (torn threads). Systems of this kind are used after bleaching or sanforization, for example.

Example 2: Fault detection

- one measuring bridge with four cameras
- two lighting devices

This system is suited for the detection of holes, weaving defects, and stains. A measuring bridge equipped with four cameras scans the product. Different faults can be detected with the incident and transmitted light modes. Systems of this kind are installed after washing and drying, for example, to detect faults prior to the finishing process.

Example 1: Hole detection

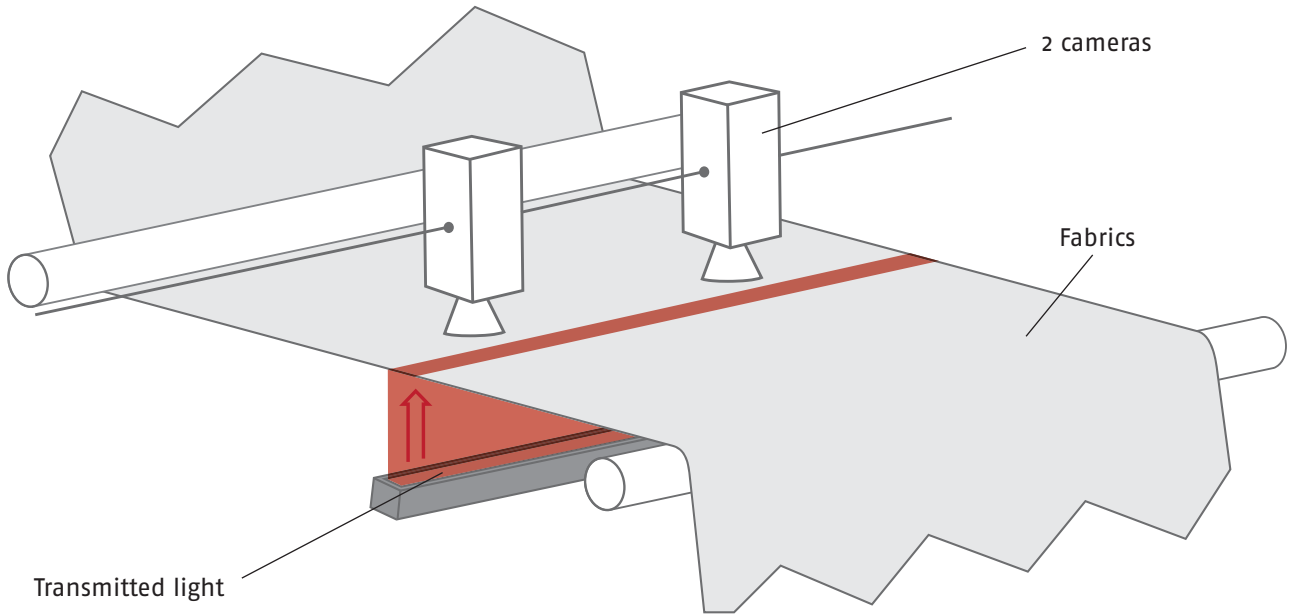

Example 2: Fault detection

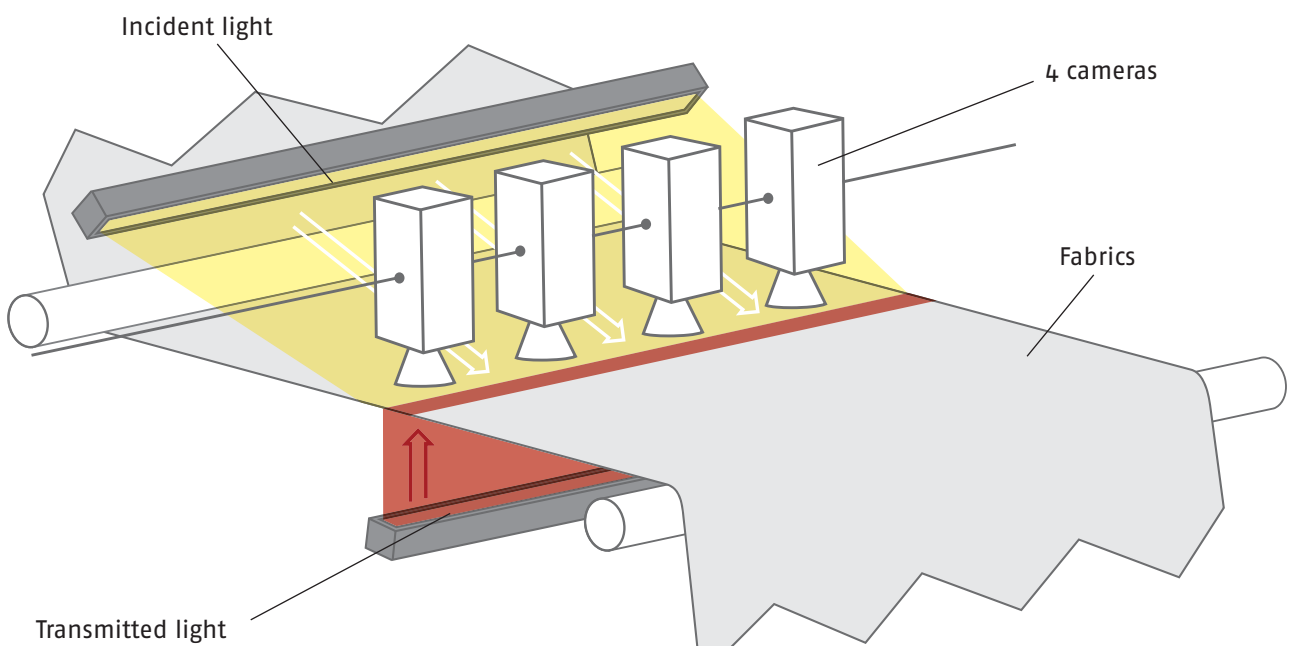



TEXTILE



NONWOVENS



PAPER



PLASTIC

WEBSCAN

EXAMPLES

APPLICATIONS

Example 3: High-end inspection system

- two measuring bridges with altogether 16 cameras
- three lighting devices

This system is suitable when multiple different lighting devices are required to detect all faults. It enables you to detect all faults on the top and bottom side in a single pass. Often combined with a Mahlo® colour measurement system (Colorscan CIS), it is ensured that the subsequent process can be performed with the highest quality and the product does not give any cause for complaint.

The following equipment is used in this example configuration:

- Measuring bridge 1: eight cameras, transmitted light devices to detect faults in the fabrics.
- Measuring bridge 2: eight cameras, incident lighting (white, switchable to UV light) to detect stains and defects with a weak contrast such as oil stains and stop spots.

The measuring bridges are enclosed to minimise any disturbing influences.

A complete set of peripheral equipment for product inspection including winding up and off devices and an inspection table is available as an extension. We also offer a variant for highly corrosive environments.

Other useful options include:

- Interfaces for the automation of all sequences
- Longitudinal cut with logging
- Width measuring and logging
- Draft measuring and logging
- Defect marking
- Synchronous marking to consider any varied product elongation during finishing
- A full set of features to adjust logs and to export data

Example 3: High-end inspection system

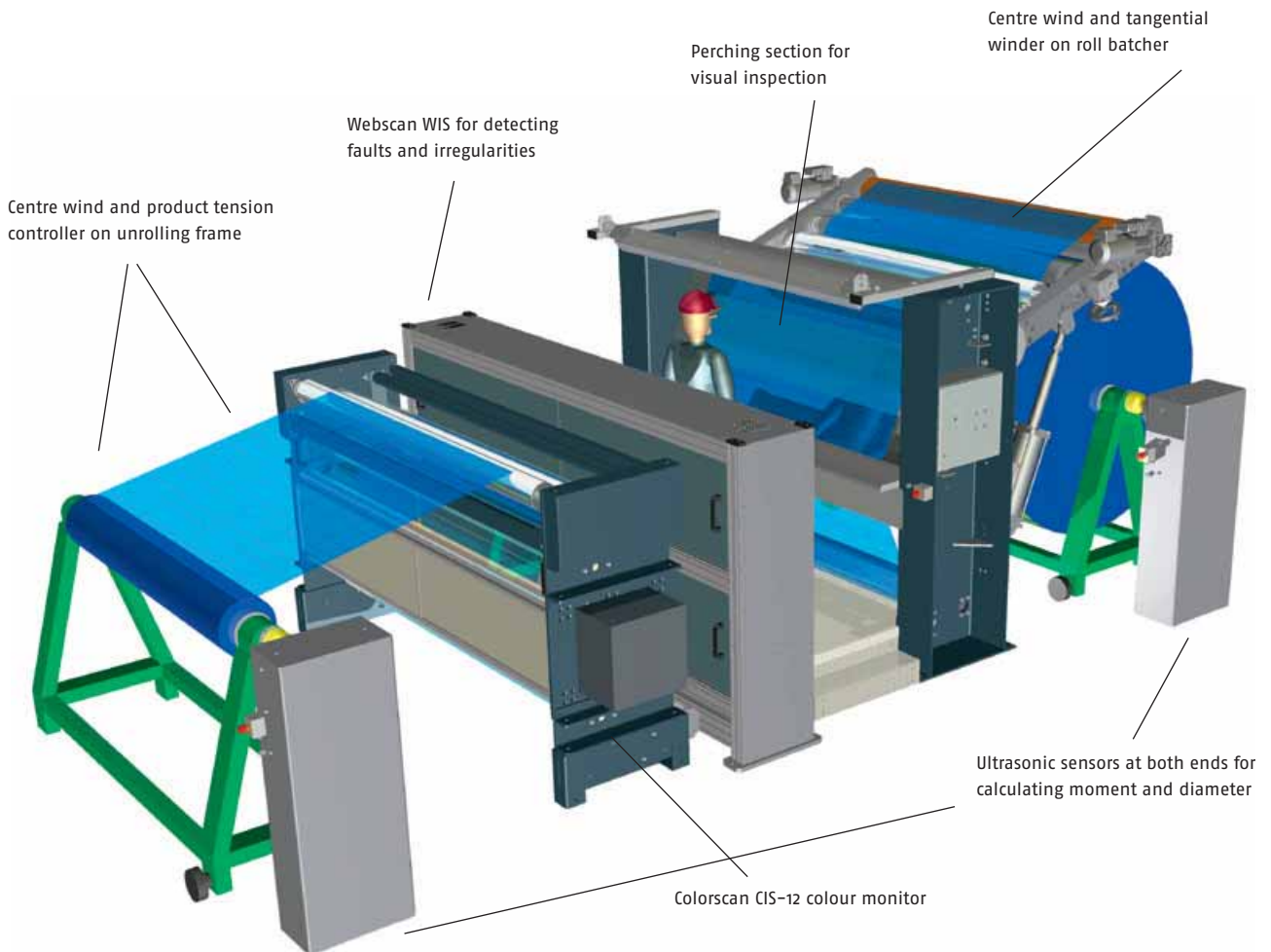

Mahlo® rewinding station with cloth inspection and colour measurement. Designed and manufactured for a large, well-known textile producer.



COLORSCAN CIS-12

Online measurement of colour with a Colorscan CIS-12 provides the following information without having to waste time sampling:

- ✓ Documents any listing and ending that may occur
- ✓ Sections of batches that exceed or fall below the specified tolerances are marked accordingly
- ✓ Sections of batches which match in colour are sorted into separate logs
- ✓ Facilitates comparison with previously dyed and finished batches
- ✓ Colour-related data is acquired continuously and displayed graphically.

The potential savings in costs allow but one conclusion: an online colorimeter from Mahlo®!

WEBSCAN



TEXTILE



NONWOVENS



PAPER



PLASTIC

PROJECT'S COURSE OF EVENTS

CUSTOMER CARE FROM A-Z

Mahlo®, along with its know-how, accompanies the customer through each phase of a project. This begins with in-depth consultations, during which the customer's specific objectives are defined. Together with a team of experts from Mahlo® the project's course of events is established, each phase of which is accompanied all the way by Mahlo®.

Information and analytical phase

Each new project begins with detailed consultations. During preliminary investigations, a qualified team of experts analyse the customer's precise needs and requisite standards. On the strength of this detailed analysis, we establish an exact specification profile of the system.

Definition and planning phase

In this phase we define exactly the specifications and course of events for the application concerned. In a specifications catalogue we place on record the requisite steps. By doing so we can ensure that the project meets all our customer's requirements.

Realization phase / commissioning

During the manufacturing phase we keep in constant touch with the customer in order that we can effect immediately any improvements that may be required. After the test phase the system is delivered and integrated into the on-site production line. It is then calibrated and put into service in accordance with the specifications.

Acceptance phase

Acceptance of the system constructed to the specifications catalogue marks the successful conclusion of the project. Fixed code numbers and benchmarks are recorded in the acceptance protocol.

Service

Our customers are exceedingly well looked after before, during, and after the project. In authorized training sessions, participants are instructed on product-related fields of application, project-related adaptations and the functionality of the system. Provision of after-sales service, regular checks on the serviceability of the system, and customer satisfaction are only a fraction of what we have to offer.

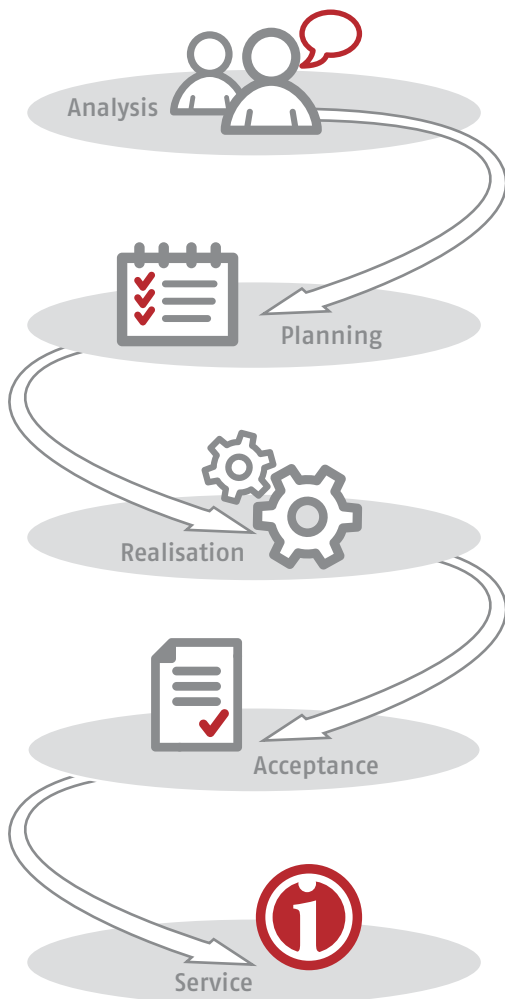

TECHNICAL DATA | WEBCAN WIS

Item	Webscan WIS
Measurement	Optical defect detection through camera equipment
Max. product width	Up to 3.20 m
Max. line-speed	80 - 120 m / min depending on the resolution and lighting
Dimensions	Depending on the product width
Power supply	1 ~ 230/115 V AC, 50/60 Hz
Ambient temperature	Max. 40 °C

Dimensions

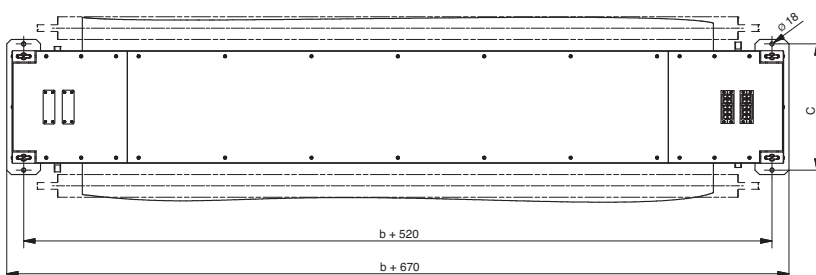
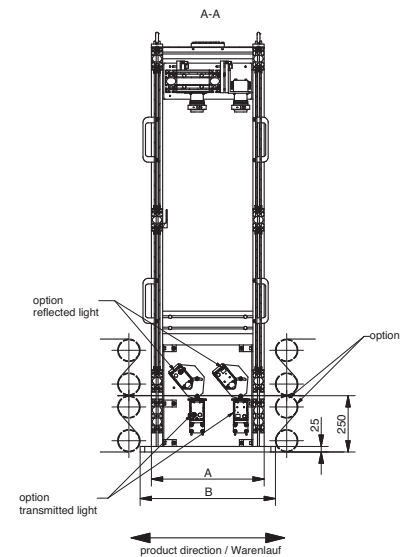
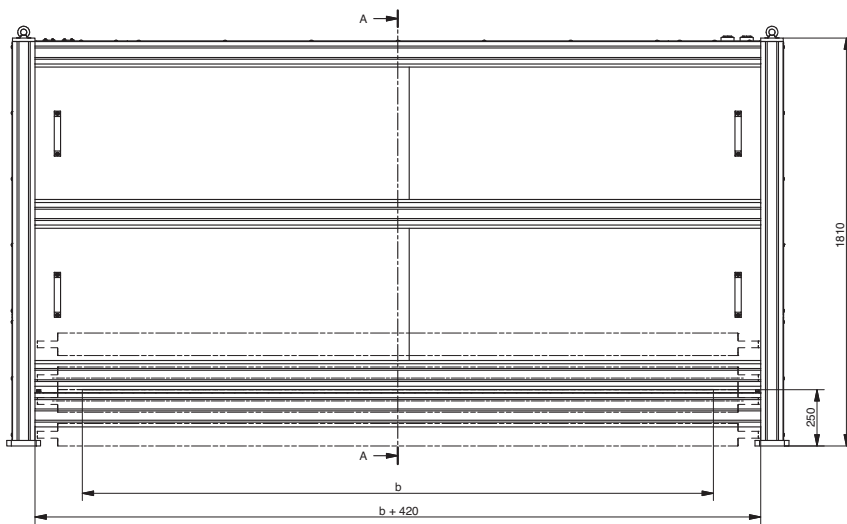

Webscan WIS with enclosure
91-015298

Monitoring and control systems, automation:

MAHLO® GUARANTEES QUALITY. WORLDWIDE, IN YOUR VICINITY.

Best-possible technical support and transfer of know-how are written in capital letters at Mahlo®. Thanks to an international network of agencies and service centres, customers have at their disposal competent support worldwide. We are there for you 365 days a year, 24 hours a day. Just get in touch with us!

- ✓ Over 40 service centres worldwide
- ✓ Prompt service and supply of spare parts within 24 hours
- ✓ Remote diagnostic system
- ✓ Service-hotline: +49-180-5062456



Overall management of Mahlo GmbH + Co. KG
and all subsidiary companies:
Ralf Hopp, Dipl.-Ing. (FH)

Mahlo GmbH + Co. KG Germany

Donaustr. 12, 93342 Saal/Donau
Contact: Ralf Hopp
Tel.: +49-9441-601-0
Fax: +49-9441-601-102
info@mahlo.com

Mahlo Italia S.R.L. Italy

Via Fiume 62, 21020 Daverio
Contact: Michel Bruni
Tel.: +39-0332-94-95-58
Fax: +39-0332-94-85-86
mahlo.italia@mahlo.com

Mahlo America Inc. USA

P.O. Box 2825, Spartanburg, S.C. 29304
Contact: Alan Lavore
Tel.: +1-864-576-62-88
Fax: +1-864-576-00-09
mahlo.america@mahlo.com

Mahlo España S.L. Spain

C/ Santa Margarida, s/n - Nave nº13
Poligono Industrial Riera de Caldes - Boada Vell
E08184 Palau Solità i Plegamans (Barcelona)
Contact: Jordi Grass
Tel.: +34-90-20062-30
Fax: +34-90-20062-40
mahlo.espana@mahlo.com

Mahlo Ouest S.P.R.L. Belgium

Quartum Center
Hütte 79 - Bte 10
4700 Eupen
Contact: Manfred Havenith
Tel.: +32-87-59-69-00
Fax: +32-87-59-69-09
mahlo.ouest@mahlo.com

Mahlo de Mexico SA de CV. Mexico

Av. del Iman 580, Edif. La Joya, Depto. 304,
Col. Pedregal de Carrasco, Del. Coyoacán D.F., CP 04700
Contact: Jordi Grass
Tel.: +52-555-606-47-52
Fax: +52-555-606-47-52
mahlo.mexico@mahlo.com

WWW.MAHLO.COM



Quality made
in Germany

1945
2005
60 YEARS
MAHLO

