

ORTHOFACT RMB-15

Automatic pin wheel straightening system

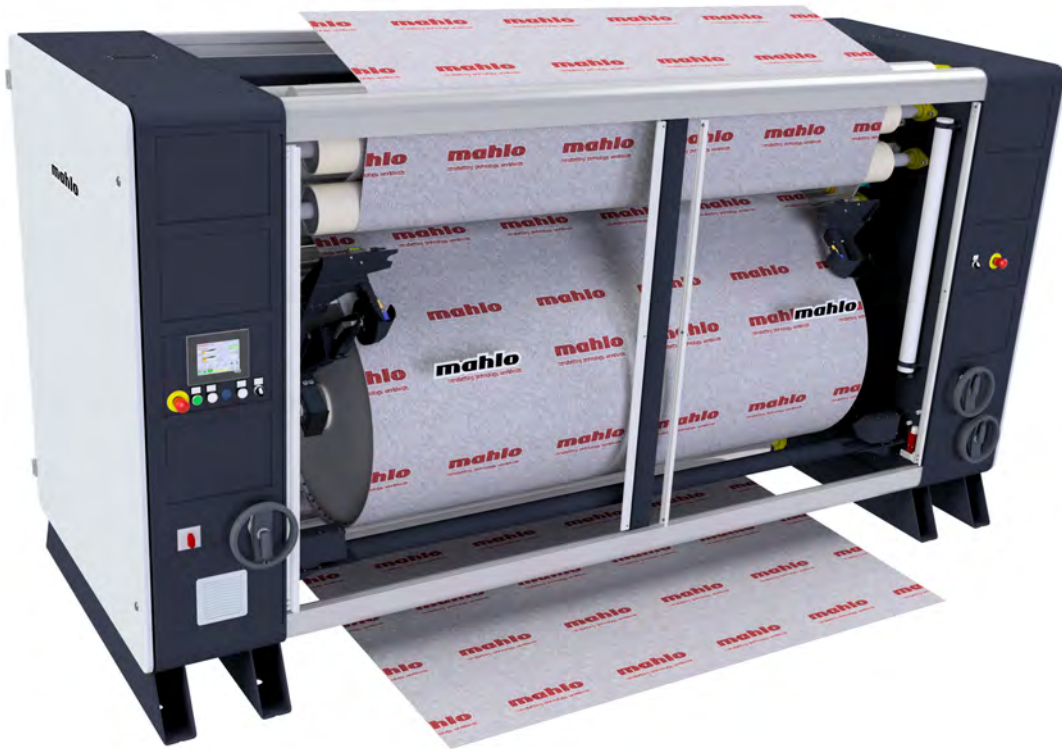

ORTHOFACT RMB-15



Quality made
in Germany



TEXTILE



NONWOVEN



COATING &
CONVERTING



PAPER



EXTRUSION

ORTHOFACT RMB-15

Automatic pin wheel straightening system



Customer benefits

- ✓ *Reliable, quick distortion correction*
- ✓ *Effective also with asymmetric distortions*
- ✓ *Increased productivity*

Removing all types of distortions

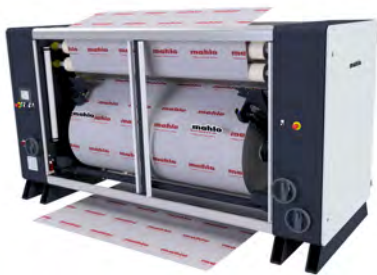

Asymmetrical distortions (wavy, S-shaped, etc.) in textiles have always represented a huge challenge in the textile industry. Distortion always means that the perpendicular structure of warp and weft threads is distorted resembling something like a parallelogram, trapezoid or other shapes.

The solution

To restore the warp and weft threads to their original state, a defined lateral tension is generated in the Orthomax RFMB using freewheeling pin wheels inclined toward each other. This cross-tension stretches the warp threads. Skew and bow distortions and even wavy or S-shaped distortions are straightened.

Patented Mahlo Technologies

Inclined positioning of the wheels is carried out pneumatically, which ensures a constant straightening effect. A counter-force – generated by a spring – compensates friction losses and tolerances and causes a uniform, symmetrical wheel alignment (patented). The optimized design considerably reduces the maintenance effort.



Product highlights

- ✓ *Lateral tension infinitely variable*
- ✓ *Adjustable unclipping device*
- ✓ *Bypass function*
- ✓ *Intelligent drive*
- ✓ *Comprehensive software with touchscreen control*
- ✓ *Pinning position adjustable during operation with software*

CHARACTERISTICS

Special features



The "Coffee break" function preserves the product during standstill.

The automatic pin wheel straightening system offers some special features.

Infinitely adjustable unclipping roller (patented): Minimises residual bow and edge distortions and preserves web edges.

Intelligent drive station: Through a special tension control for smallest web tension the drive activates or deactivates automatically (e.g. in case of blockages). A **bypass function is available at the push of a button for products that cannot be straightened with the pin wheel.**

Intelligent wheel following: Product loss is nearly prevented entirely. The control immediately compensates product offset, poor seams, fringes and dents on the edges.

Width jump function: New wider webs do not need to be pulled in separately when changing products. Sew the new product to the old one, pull in, done! No more downtime!

Break function: This feature reduces the lateral tension to a pre-selected level when the line is stopped, e.g. during breaks or when working on other machines in the line. Preserves the product!

Advantages of the new device generation

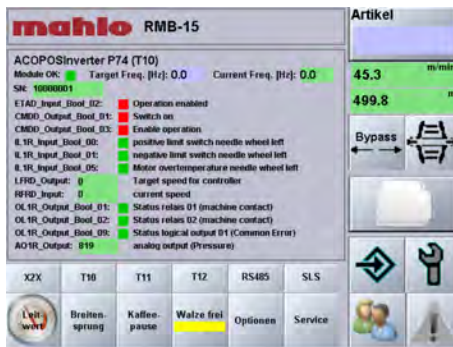

Diagnostic functions precisely analyse the condition of the device.

Large straightening capacity: Through a higher pinning point the spreading utilises almost the entire diameter of the straightening wheel. This ensures a high straightening effect.

Automatic wheel cleaning (option): Automatic cleaning of the pin wheels can now be started as software function. Manual operation is no longer required.

Extended diagnostics: The software features significantly expanded diagnostic functions. Past alarms can be analysed in the alarm history. Remote maintenance is possible via a remote function.

PICTURES

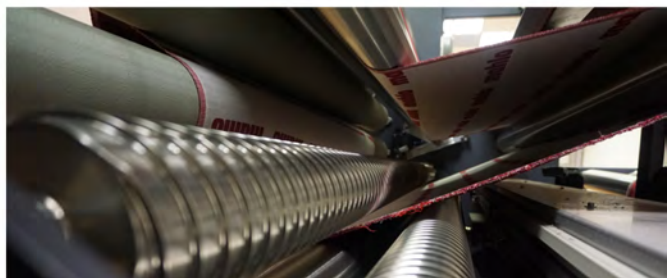
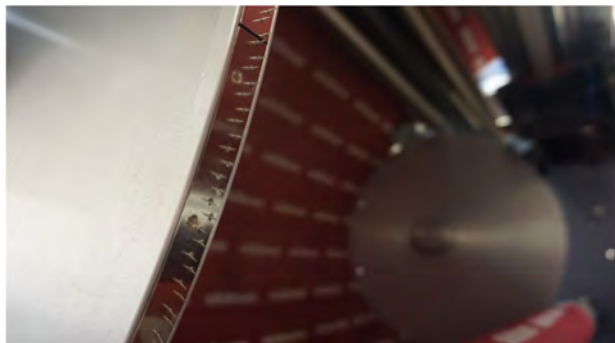
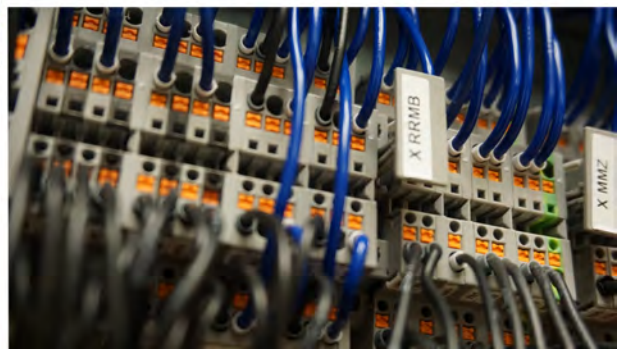

SERVICE AND SUPPORT

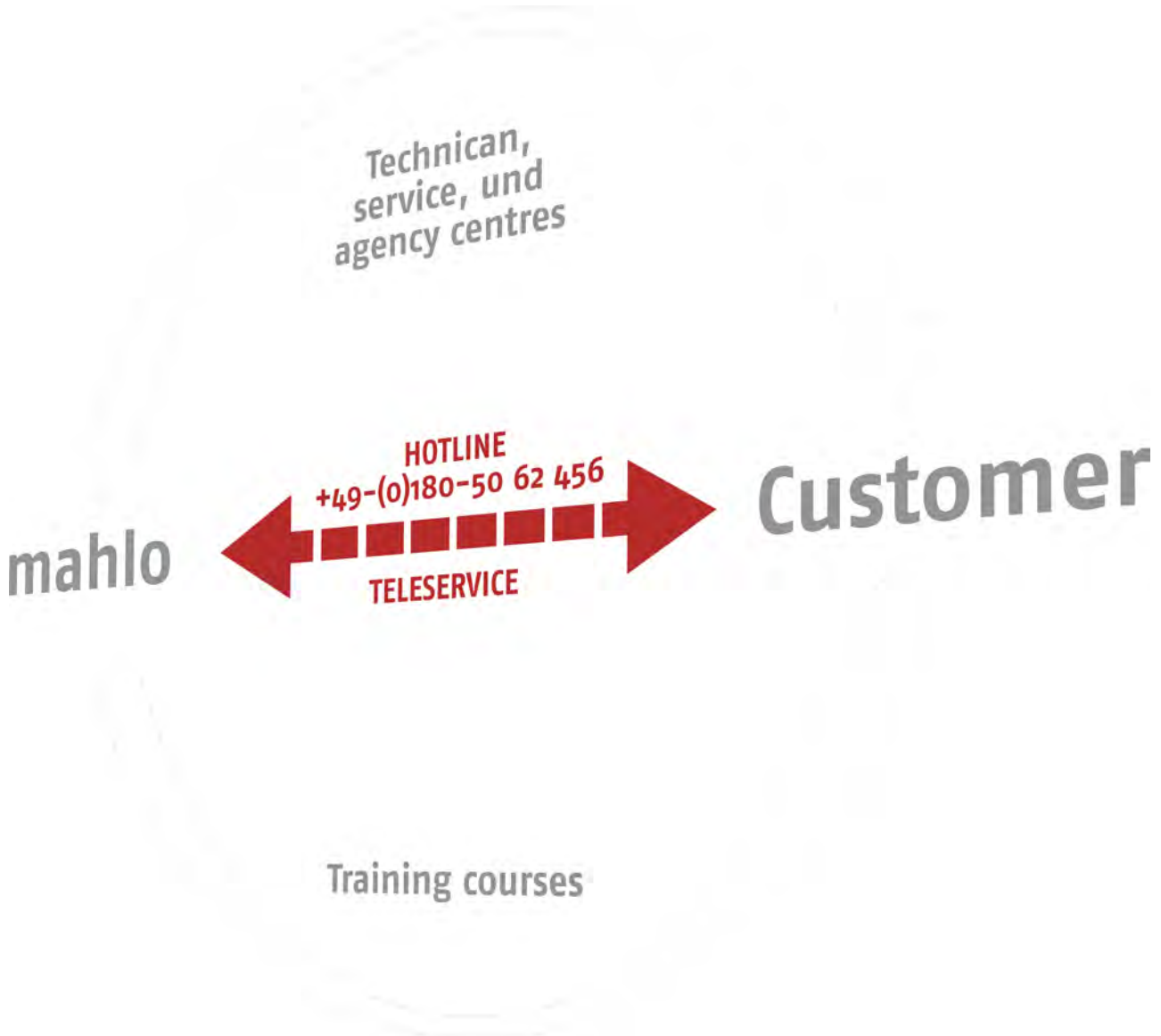

With innovative and trend-setting technology, Mahlo has been setting standards for decades in the field of measuring and control systems for the industry sectors of textiles, nonwovens and finishing, laminating, coating & converting, film and extrusion as well as cellulose, paper and calendering.

In addition to the technology, direct contact with our customers is especially important to us. This includes intensive assistance and customer care wherever the customer is located and a global service and representative network including 24-hour replacement part service.

Mahlo customers can safely count on the know-how of our experts in any situation, whether installation and startup, conversion of existing systems or maintenance of their machines.

TECHNICAL DATA

Specification	Value
Straightener	2 pin wheels
Product guidance	Needle strips on straightening wheels
Drive mechanism traversing movement	Asynchronous motor
Drive mechanism straightening wheel swivel movement	Pneumatic cylinder

Specification		Value	Unit
Nominal product width		1000 - 3200	mm
Product speed, maximum	Standard	8 - 80	m/min
	Options	3 - 40	
		12 - 120	
Lateral tension		0 - 1500	N
Length tension, maximum (drive station)		1000	N
Pin wheels: Theoretically max. possible straightening effect (at full utilization of the nominal product width)		450 ¹	mm
Diameter straightening wheel		800	mm
Weight (approx.)		3400 ¹	kg
Power supply		3 x 400 ±10 %	VAC
Line frequency		50	Hz
Power consumption, maximum		6,3	kVA
Working pressure		6	bar
Compressed air consumption		40	l/min
Temperature range		5 - 45	°C

¹⁾ Example: Nominal product width 2000 mm

Dimensions

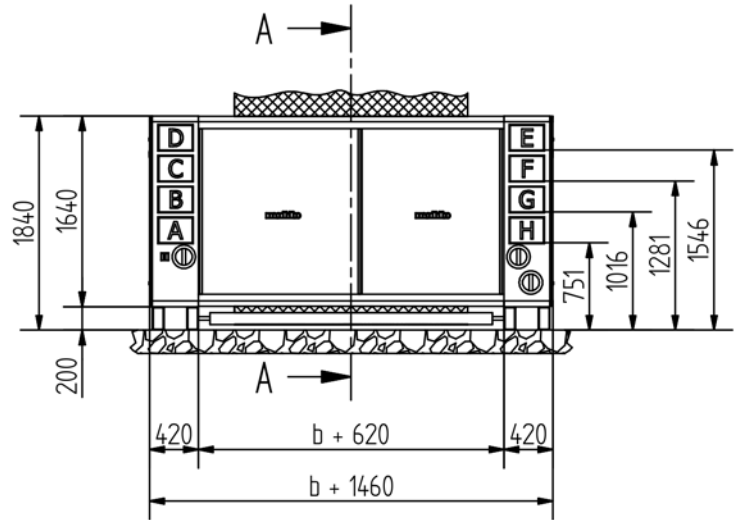
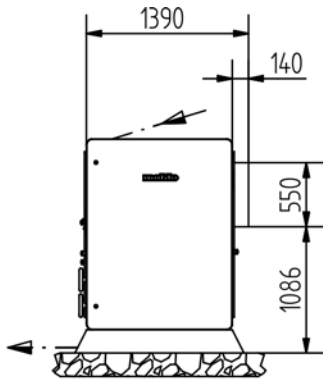

A-A

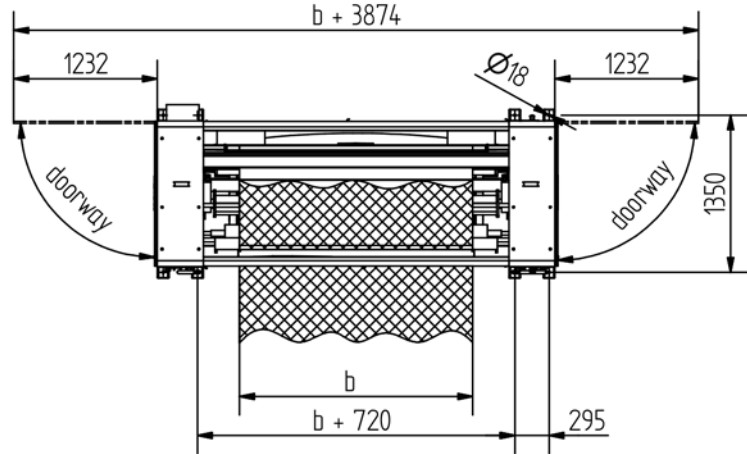
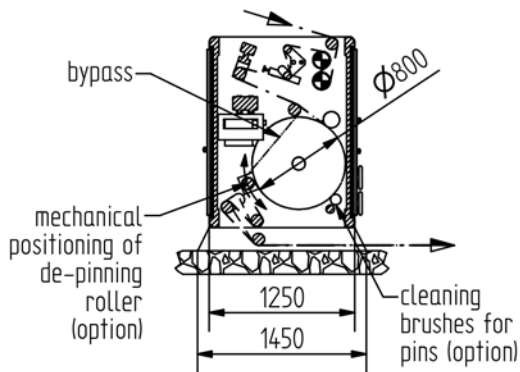

The operating units can be placed free on the positions A to H

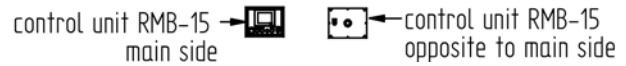

Orthofact RMB (91-019499)

Monitoring and control systems, automation:

MAHLO GUARANTEES QUALITY. WORLDWIDE, IN YOUR VICINITY.

Best-possible technical support and know-how transfer are written in capital letters at Mahlo. Thanks to an international network of agencies and service centres, customers have at their disposal competent support worldwide. We are there for you 365 days a year, 24 hours a day. Just get in touch with us!

- ✓ Over 40 service centres worldwide
- ✓ Service partners in over 100 countries
- ✓ Direct service and spare parts delivery within 24 hours
- ✓ Remote diagnostic system
- ✓ Service Hotline: +49-180-5062456



Mahlo GmbH + Co. KG - Germany

Donastr. 12
93342 Saal / Donau
Telephone: +49-9441-601-0
Fax: +49-9441-601-102
Email: info@mahlo.com

Mahlo Italia S.R.L. - Italy

Via Fiume 62
21020 Daverio
Telephone: +39-0332-94-95-58
Fax: +39-0332-94-85-86
Email: mahlo.italia@mahlo.com

Mahlo America Inc. - USA

575 Simuel Road
Spartanburg S.C. 29304
Telephone: +1-864-576-62-88
Fax: +1-864-576-00-09
Email: mahlo.america@mahlo.com

Mahlo Ouest S.P.R.L. - Belgium

Quartum Center
Hütte 79 - Bte 10
4700 Eupen
Telephone: +32-87-59-69-00
Fax: +32-87-59-69-09
Email: mahlo.ouest@mahlo.com

Mahlo España S.L. - Spain

Calle Luxemburgo nº 4
08303 Mataró (Barcelona)
Telephone: +34-938-640-549
Email: mahlo.espana@mahlo.com

WWW.MAHLO.COM