

SAMPLECUT FSC-12

On-line sample cutter

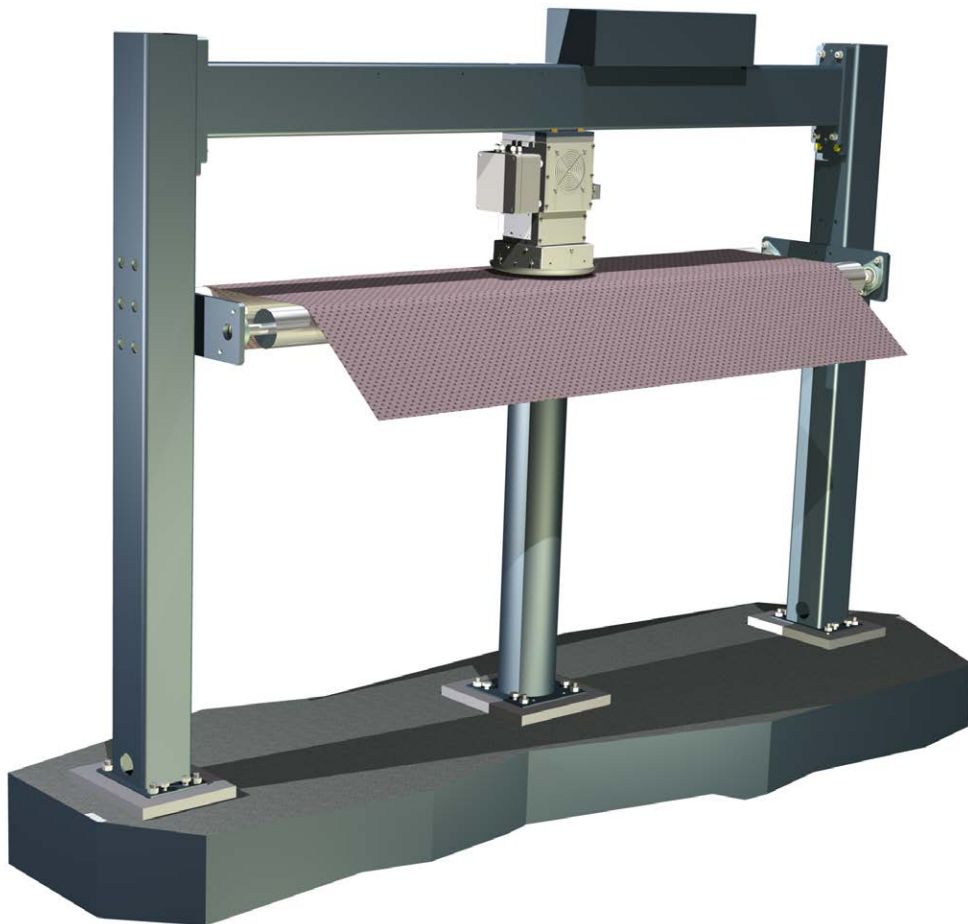

SAMPLECUT FSC-12



Quality made
in Germany



TEXTILE



NONWOVEN



COATING &
CONVERTING



PAPER



EXTRUSION

SAMPLECUT FSC-12

Area of application



Principle of operation

Sample cutting online – without having to stop the machine



Customer benefits

- ✓ Takes samples from online materials
- ✓ No downtimes as a result of sampling
- ✓ Simplicity itself to operate
- ✓ Increases productivity
- ✓ Ensures a more efficient use of processing machinery

To monitor the progress of certain processes there is no alternative but to take frequent samples at the machine itself. However, this can only be done whilst the material is at a standstill or running slowly, and often leads to all manner of ambitious, sometimes absurd measures to enable the process to run continuously (non-stop batching, etc.).

Mahlo offers the solution to this problem with the Samplecut FSC. The Samplecut FSC system is installed e.g. at the outlet of the stenter frame at a suitable point. The pneumatic unit operates at high pressure and presses a circular knife with a diameter of 200 cm² through the fabric against a counterpart in a fraction of a second. The pattern is punched out and is guided to the operating side via the sampling device.

Advantage: An exact 100 cm² pattern can be cut from the sample in the laboratory.

Equipment

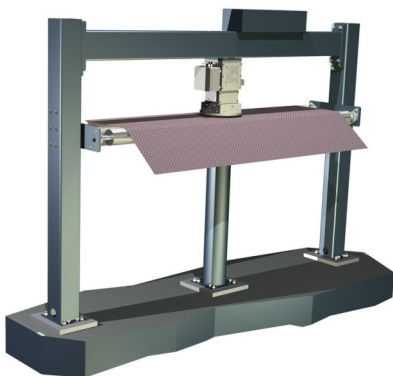

Product highlights

- ✓ Sampling at maximum line-speeds
- ✓ Punching in fractions of a second
- ✓ Increases the efficiency of production machinery
- ✓ Robust, simple construction

The tried and tested Samplecut FSC appliance cuts samples from the high-speed product, and comprises in essence

- Circular blade (A: 200 cm²)
- Pneumatic unit
- Sample chute
- Control panel
- Switch panel

Control element

The operator need only press a button to release the sample via the control panel.

TECHNICAL DATA

Angabe	Wert	Einheit
Measuring principle	Fixed sample cutter	
Size Samples ¹	200	cm ²
Power supply	230 / 400	VAC
Line frequency	50 / 60	Hz
Power supply	5 - 45	°C

1) other dimensions possible on request

Dimensions

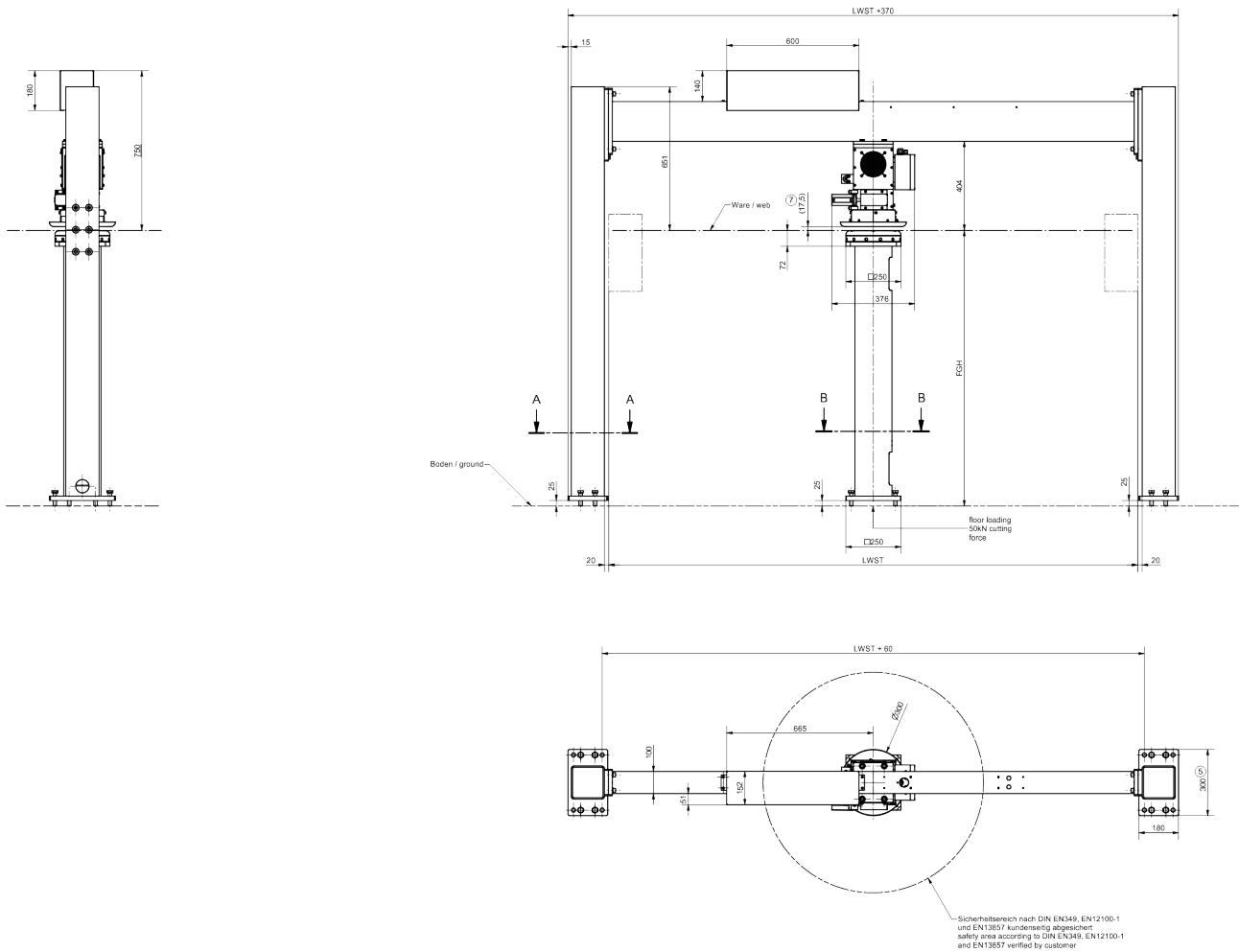

Samplecut FSC-12 (91-014654-006)

Monitoring and control systems, automation

MAHLO GUARANTEES QUALITY. WORLDWIDE, IN YOUR VICINITY.

Best-possible technical support and know-how transfer are written in capital letters at Mahlo. Thanks to an international network of agencies and service centres, customers have at their disposal competent support worldwide. We are there for you 365 days a year, 24 hours a day. Just get in touch with us!

- ✓ Service partners in over 100 countries
- ✓ Direct service and spare parts delivery within 24 hours
- ✓ Remote diagnostic system
- ✓ Service Hotline: +49-180-5062456
- ✓ WWW.MAHLO.COM



Mahlo GmbH + Co. KG - Germany

Donastr. 12
93342 Saal / Donau
Telephone: +49-9441-601-0
Fax: +49-9441-601-102
Email: info@mahlo.com

Mahlo Italia S.R.L. - Italy

Via Fiume 62
21020 Daverio
Telephone: +39-0332-94-95-58
Fax: +39-0332-94-85-86
Email: mahlo.italia@mahlo.com

Mahlo America Inc. - USA

575 Simuel Road
Spartanburg S.C. 29304
Telephone: +1-864-576-62-88
Fax: +1-864-576-00-09
Email: mahlo.america@mahlo.com

Mahlo Ouest S.P.R.L. - Belgium

Quantum Center
Hütte 79 - Bte 10
4700 Eupen
Telephone: +32-87-59-69-00
Fax: +32-87-59-69-09
Email: mahlo.ouest@mahlo.com

Mahlo España S.L. - Spain

Calle Luxemburgo nº 4
08303 Mataro (Barcelona)
Telephone: +34-938-640-549
Email: mahlo.espana@mahlo.com